



# DECKING & DRYSPACE™

## INSTALLATION & MAINTENANCE GUIDE

| DECKING  
RAILING

| LIGHTING  
ACCESSORIES

| [www.timbertech.com](http://www.timbertech.com)

September 2012

# Decking Product Choices

With a wide selection of plank styles and profiles – available in a variety of colors, TimberTech decks are easy to design, build and maintain.

		Cedar	Grey	Redwood	Brown Oak	Silver Maple	Brick	Brownstone	Slate	Pacific Rosewood	Pacific Teak	Pacific Walnut	RiverRock	SandRidge	Mountain Cedar	Harbor Stone	Harvest Bronze	RusticBark	Walnut Grove	Wt.* Lbs/Each	Qty/ Unit
<b>DECKING PLANKS</b>																					
XLM® Solid	1" x 5.430" x 16', 20'												X	X	X	X	X	X	X	29, 36	64
XLM® Grooved	1" x 5.430" x 12', 16', 20'												X	X	X	X	X	X	X	20, 29, 35	64
Earthwood Evolutions® Solid	0.94" x 5.360" x 16', 20'						X	X	X	X	X	X								41, 51	64
Earthwood Evolutions® Grooved	0.94" x 5.25" x 12', 16', 20'						X	X	X	X	X	X								29, 39, 49	64
Earthwood Evolutions® Terrain Grooved	0.94" x 5.25" x 12', 16', 20'				X	X														24, 32, 40	64
Earthwood Evolutions® Terrain Solid	0.94" x 5.25" x 16'				X	X														32	64
TwinFinish® Solid	1" x 5.360" x 16', 20'	X	X	X																47, 58	64
TwinFinish® Grooved	1" x 5.360" x 12', 16', 20'	X	X	X																34, 45, 56	64
ReliaBoard® Solid	0.94" x 5.360" x 12', 16', 20'	X	X																	29, 37, 48	64
DockSider® Solid	1.25" x 5.5" x 12', 16', 20'	X	X																	45, 60, 75	48
<b>DECKING ACCESSORIES</b>																					
Earthwood Evolutions® Fascia	.560" x 12" x 12'						X	X	X	X	X	X									
Earthwood Evolutions® Riser	.560" x 7.250" x 12'						X	X	X	X	X	X									
TwinFascia®	.560" x 12" x 12'	X	X	X																45	30
TwinRiser®	.560" x 7.250" x 12'	X	X	X																27	42
XLM® Fascia	.560" x 12" x 12'											X	X	X	X	X	X	X	X	30	30
XLM® StairRiser	.560" x 7.250" x 12'											X	X	X	X	X	X	X	X	18	42
CONCEALoc® Fasteners - Retail Carton	100 sq. ft. coverage																			4	8
CONCEALoc® Fasteners - Bulk Bucket	1000 sq. ft. coverage																			43	1
CONCEALoc® Fasteners - Gun Pail	500 sq. ft. coverage																			20	1
CONCEALoc® Replacement Screws	50/Retail Pack																			0.4	20
CONCEALoc® L-Bracket	50/Retail Pack																			1	10
CONCEALoc® Router Bit	1/Retail Pack																			0.5	6
Cortex® Hidden Fastening System	100 lin ft.	X	X	X			X	X	X	X	X	X	X	X	X	X	X	X	X	3	6
TOPLoc™ Face Fastener - Retail Carton**	100 sq. ft. coverage	X	X	X	X	X	X	X	X	X	X	X	X	X	X	X	X	X	X	4	8
TOPLoc™ Face Fastener - Bulk Bucket**	500 sq. ft. coverage	X	X	X	X	X	X	X	X	X	X	X	X	X	X	X	X	X	X	19	1
TOPLoc™ Fascia Fastener**	100 In. ft. coverage	X	X	X	X	X	X	X	X	X	X	X	X	X	X	X	X	X	X	1	15
TOPLoc™ Stainless Steel	85 sq. ft. coverage	X	X	X			X	X	X	X	X	X	X	X	X	X	X	X	X	4	8

\* Weights are rounded to nearest lb.

\*\*TOPLoc is available in Cedar, Grey, Rosewood, Teak, and Walnut but is made to match all color profiles.

\*\*\*Cortex is not for ReliaBoard or Earthwood Evolutions Terrain.

**TimberTech recommends visiting your local Dealer to view actual profiles and color selections.**

# Installing TimberTech

## TimberTech covers the alternative decking market

To get information on other TimberTech products visit [timbertech.com](http://timbertech.com) or ask your dealer for these installation guides:

- **TimberTech Railing & DeckLites® Installation & Maintenance Guide**
- **TimberTech FenceScope® Installation & Maintenance Guide**

These installation guidelines will direct you through the process of installing TimberTech products. Most installers will find this process similar to the installation of a wood deck. However, there may be areas that differ from what you are used to.

These installation methods are recommended by TimberTech, but they may not cover every installation scenario you may encounter. Since each installation is unique in its performance requirements, the ultimate installation method used is the sole responsibility of the installer. TimberTech recommends that all designs be reviewed by a licensed architect, engineer or local building official before installation. Make sure your plans meet local building codes before you begin the installation.

## Tools Required

TimberTech planks can be installed with a minimum number of readily available tools. However, many other tools are available that can provide even greater efficiency and ease of installation. All tools should be used per applicable manufacturers' instructions. Some of the basic tool requirements:

- Cordless Driver
- Chalk Line
- Tape Measure
- Jig Saw
- Carpenter Square
- Spacing Tools
- Circular Saw
- Safety Glasses

Use the jigsaw to cut around obstructions such as posts. A power miter saw can also be very helpful during installation. When cutting XLM planking with a hand held circular saw it is recommended that a thin kerf 40-tooth alternate top bevel finish blade be used to achieve the cleanest cuts. For a power miter or compound power miter saw a fine finish alternate top bevel blade is also recommended. When working with TimberTech products be sure to wear proper clothing and safety equipment. Safety glasses should be used during the entire installation process.

## STOP! Read this section before you start!

For most current care and cleaning, technical information and more, visit [www.timbertech.com](http://www.timbertech.com).

**Floorizon** — For information on Floorizon please visit [www.timbertech.com](http://www.timbertech.com) and click on Installation Resources for downloadable instructions.

- XLM** —
- TimberTech does not recommend the use of rubber or vinyl products (welcome mats, planters, etc.) on XLM deck planks. A reaction can occur that causes discoloration of the decking under the rubber/vinyl product. This is a common caution for vinyl decking products.
  - Do NOT nail XLM Planks

**Walking Surface** — TimberTech planks are intended to be installed embossed side up. The unembossed surface is not to be used as a walking surface. This applies to all decking surfaces.

**Directional Notch** — TimberTech's surface on TwinFinish, ReliaBoard, Earthwood Evolutions, DockSider, TwinFascia and TwinRiser boards is directional in manner. A notch has been added to one side of the planks. When installing planks, this marked edge must be laid to the same side for the entire installation for a consistent appearance. Similarly, TimberTech's TwinFascia board and TwinRiser have one long beveled edge on the front and back. To ensure a consistent appearance from board to board, the beveled edge must be laid to same side. If you rip a piece, be sure to note the location of the bevel. See individual plank installation instructions.

**Static Electricity** — Static build-up is a natural occurring phenomenon that can occur with many plastic products. It could occur with TimberTech products under the right environmental conditions.

**Cantilevering** — TimberTech XLM, Earthwood Evolutions, TwinFinish, ReliaBoard, and DockSider can be cantilevered a maximum of 1".

**Color and Grain Patterns** — Our wood-plastic composite deck boards are designed to mimic the look of real wood, and like real wood, there will be a slight difference in color and grain pattern from board to board. This is intentional and part of the manufacturing process, giving TimberTech wood-plastic composite decking the most realistic and wood-like appearance possible. This variation is purely aesthetic and does not or will not affect the performance of the product. Our deck boards are designed to naturally weather over time and the surface pattern will weather to a consistent color. Most of the weathering process will be complete within the first year of the deck's life.

**Safety** — TimberTech offers products that meet the American with Disabilities Act (ADA) guidelines for slip-resistant walking surfaces, and unlike traditional wood, TimberTech is splinter-free.

**Note** — TimberTech is **NOT** intended for use as columns, support posts, beams, joist stringers or other primary load-bearing members. TimberTech must be supported by a code-compliant substructure. While TimberTech products are great for deck re-planking (removing old deck surface planks and installing TimberTech on code-compliant substructure), TimberTech planks **CANNOT** be installed on top of existing deck planks.

**Routing** — TimberTech TwinFinish, DockSider and ReliaBoard may be routed for accents such as adding an edge radius. **XLM and Earthwood Evolutions SHOULD NOT** be routed aside from routing a groove in the side of solid planks for start/stop of CONCEALoc.

## Extreme Heat Warning

Be aware of excessive heat on the surface of TimberTech products from external sources such as but not limited to fire or reflection of sunlight from energy efficient window products. Low-emissivity (Low-E) glass can potentially harm TimberTech products. Low-E glass is designed to prevent passive heat gain within a structure and can cause unusual heat build-up on exterior surfaces. This extreme elevation of surface temperatures, which exceeds that of normal exposure, can possibly cause TimberTech products to melt, sag, warp, discolor, increase expansion/contraction, and accelerate weathering.

Current or potential TimberTech customers that have concerns about possible damage by Low-E glass should contact the manufacturer of the product which contains Low-E glass for a solution to reduce or eliminate the effects of reflected sunlight.

## Excessive Construction Debris

It is important during construction, the deck's surface stay clear from excessive build-up of dirt, sand, and dust from tile, concrete, landscape blocks, or any other masonry products. If these materials are not removed immediately, the deck surface will become difficult to clean and foot traffic can potentially damage the deck's surface finish.

If a build-up does occur please refer to the Care and Cleaning section in TimberTech's installation guide.

## Calculating Material Requirements

To determine how much TimberTech decking material you will need, start by calculating the square footage of your deck surface by multiplying length by width. Once you know this number, divide it by the numbers provided below for 12' planks, 16' planks and 20' planks.

When calculating the amount of decking you will need, it is recommended that you add roughly 10% to the total for a scrap factor.

### **XLM, Earthwood Evolutions, TwinFinish, ReliaBoard Plank, and DockSider**

Once you know the square footage number, divide it by 5.5 for 12' planks, 7.3 for 16' planks and 9.1 for 20' planks.

**Example:** Length x Width = Total Square Footage

Square Footage ÷ by 5.5 (12'), 7.3 (16') or 9.1 (20') = Planks Needed  
(Round the number up)

Planks Needed + 10% (Scrap Factor) = Final Number of Planks  
Needed (Round the number up)

---

## Working With TimberTech Planks

### Expansion and Contraction

TimberTech deck planks will experience expansion and contraction with changes in temperature. Expansion and contraction are most significant where extreme temperature changes occur. Fastening the deck planks according to the gapping requirements noted in the following table accommodates for this movement.

Changes in length are most significant during the installation process, and should be accounted for if working in extreme temperatures. A good example would be cutting your planks during a hot afternoon, letting them sit outside overnight in the cool air and then installing them the next morning. Chances are, you will notice a certain amount of contraction. The best way to minimize this problem is to fasten your planks as soon after cutting as possible.

### Gapping Requirements For All TimberTech Planks

- Side to side plank gapping must be minimum 1/8" to maximum 5/32"
- Gap planks a minimum 1/8" to 3/16" side-to-side
- For California fire requirements, please refer to page 17.
- Allow 3/16" minimum gap where the planking meets any adjoining structure or post.
- Follow these butt joint gapping guidelines for all TimberTech planks:

Butt Joint Gapping Requirements		
32° F and below	33° F to 74° F	75° F and above
3/16" gap	1/8" gap	1/32" gap

# CONCEALoc™ Hidden Fasteners and L-Brackets for use with TimberTech Grooved Planks - Earthwood Evolutions™, TwinFinish® and XLM®

Visit [www.timbertech.com/installation](http://www.timbertech.com/installation) to view TimberTech installation videos.

## CONCEALoc Accessories

- CONCEALoc Hidden Fasteners – retail box for 100-square-foot coverage or bulk bucket for 1,000-square-foot coverage. Includes Stainless Steel screws.
- CONCEALoc Gun Pail – 500-square-foot coverage for use with the fastener installation gun sold separately by TigerClaw. Includes quality coated pneumatic fasteners. Stainless Steel fasteners for coastal applications available through TigerClaw.
- L-Bracket – avoid face-screwing by using the L-Bracket on first and last boards or as a butt seam clip to ensure a fastener-free surface.
- CONCEALoc Router Bit – cut the correct groove dimension on a solid plank for a perfect CONCEALoc fastener fit – even allows for cutting an installed plank over a joist
- CONCEALoc screw packs available through [www.timbertechstore.com](http://www.timbertechstore.com)



## Important Information

- Warning! Parts have sharp points and edges. Use caution when handling and installing. Wear safety glasses at all times.
- In areas with obstructed airflow such as roofs and on-grade applications, a minimum of 1-1/2" is required.
- Sleeper system must be supported by and connected to the substructure over which the deck is built.

## CONCEALoc Hidden Fastener Installation Instructions

### 1 Install the First Plank

- Pre-drill with 5/32" drill bit and fasten outer edge of the first plank at each framing support 1" from the edge using TOPLoc or a #8 x 2-1/2" stainless steel or other high-quality coated deck screws. For a complete fastener-free surface, the L-Bracket can be used on first and last boards.

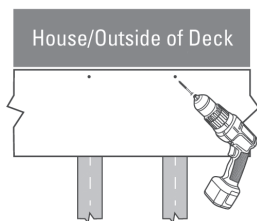

### 2 Position CONCEALoc Fasteners

- Fully insert the CONCEALoc fastener into grooved edge of plank. Screw hole should be lined up with the center of support joist.

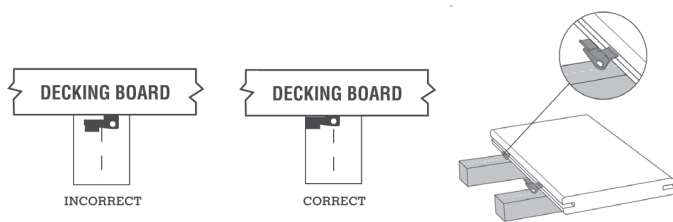

### 3 Install CONCEALoc Fasteners

- Install provided screw at 45° angle through the fastener and into the joist while applying pressure on the fastener.
- Install one fastener and screw at each joist.
- Make sure fastener is in full contact with edge of plank and the screw is holding the fastener down tight to the deck board.

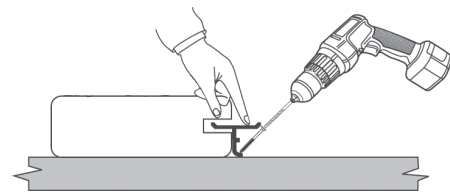

### 4 Complete Installation

- Place the next plank into position against the fasteners. Slightly raise the outer edge of the plank being installed and slide it onto the fastener until the plank contacts the spacer tab. When properly installed the inserted plank should be in contact with the bent-forward spacer tab at the left end of the clip. To achieve this use a scrap piece of decking at least 24" in length and use it as a tamping block to drive the plank further onto the clip and the screw will fully engage the plank to the spacer tab if not already in contact. Do not use a hammer or damage to the edge of the plank may occur.

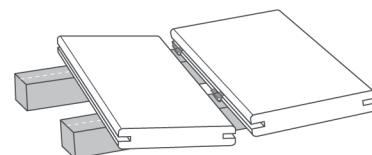

- The last plank will need to have the outside edge attached using the method described in Step #1. It may be necessary to rip the last plank to fit.

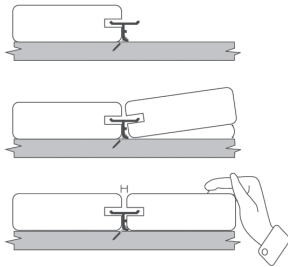

## 5 How to Install at Butt Joints (unless using TimberTech L-Bracket)

- ⚠ Joists at butt joints must be doubled up for proper fastener attachment.
- ⚠ Install fasteners as detailed below. Note that the two clips on the right are shifted approximately 1/4" to the right of center on the joists. If this is not done the spacer tab may fall within the gap of the butt joint.

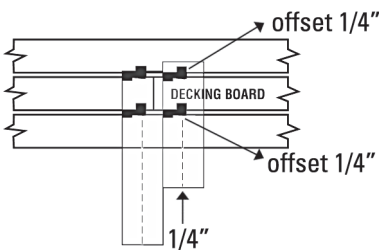

## 6 How to Install on Diagonal

- When the deck is located in a corner of the house, start with small triangular piece of decking in the corner and work your way out.
- Offset the clip 1/2" to the right of center line of the joist, so screw will not exit the side of the joist when driven.

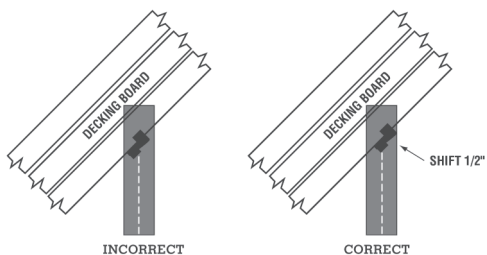

## 7 How to Replace a Plank

- Make two parallel cuts down the center of the board to be replaced, then remove the center piece.
- Using a small pry bar, remove the remaining pieces of decking from the tabs.
- Using a reciprocating saw, remove the tabs on the side of the board with the screw heads showing.
- Position new board into place, and drive onto remaining tabs.
- Once the board is set into position, secure the loose edges with stainless steel or high-quality coated deck screws.

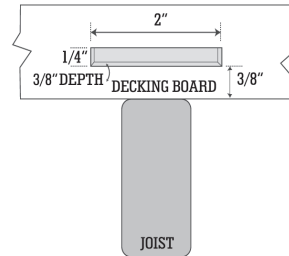

## 8 To use CONCEALoc Hidden Fasteners with TimberTech Solid Planks

Create a 2" long groove on the edge of the plank at every joist.

- Use TimberTech's CONCEALoc Groove Cutting Router Bit or a Freud model #56-112 or Bosch model #85610M 1/4" slot cutting bit.
- Flip the plank over and start the groove 3/8" off the bottom of the plank.
- Set the depth of the cut from 7/16" to 1/2" deep.

Note: Be sure to ID the side of the plank that has the directional notch; the planks with IDs should be installed to the same side. See Directional Notch on page 8.

⚠ ReliaBoard cannot be grooved. It must only be face fastened. Grooving ReliaBoard will void the warranty.

⚠ Do Not Use CONCEALoc Hidden Fasteners or L-Brackets for stair installation.

# Cortex<sup>®</sup> Hidden Fastening System

Visit [www.timbertech.com/installation](http://www.timbertech.com/installation) to view TimberTech installation videos.

## Cortex<sup>®</sup> Hidden Fastening System Installation Instructions

### Suggested Drills:

Corded drill with 1/2" chuck

Cordless drill with 1/2" chuck and 18V battery

**NOTE:** Impact Drivers are not recommended when using TimberTech Cortex.

### 1 Drive Screw

- Using Setting Tool provided, drive screw at medium or high speed until it disengages at the proper level below the deck surface.
- Drive at one continuous speed – do not slow down.



### 2 Install Deck Screws into Joists

- Install two screws into decking at each joist.
- Maximum spacing between each row of screws should be 16" on center.



### 2 Install Plug

- Place plug into cored hole and gently tap flush with deck surface.

### Important Information

- The Cortex Setting Tool must be used to set the Cortex screw to the proper depth.
- The Cortex fastener must be driven perpendicular to the deck surface for proper fit and ideal finished look.
- The cored hole must be free of debris or moisture. Use a smooth hammer head to set the Cortex plug.
- The interaction between the deck board, screw, and plug is essential. Use of non-Cortex Screws or non-Cortex plugs will nullify the warranty.

### End and Edge Distance Minimums

- Predrilling is required when installing Cortex fasteners less than 1" from the end and 1" from the edge of a TimberTech deck board.
- Predrilling is also required at butt joints. Common building practices dictate that you "sister" an additional joist at your butt seam connections.
- Predrilling should be done with a 5/32" drill bit to create the proper pilot hole.

### Restricted Cortex Uses

The TimberTech Cortex System is designed for traditional elevated deck surfaces. The following applications require a different fastening method for further instructions:

- Sleeper systems: Framing rests directly on the ground or roof deck.
- For attaching fascia boards. TimberTech TOPLoc should be used in this application.
- Docks or decks with framing members in constant contact with saltwater.
- Restricted airspace when there is less than 12" of clearance on 3 sides of the deck.
- Deck materials OTHER than 1" standard thickness (usually labeled as 5/4").

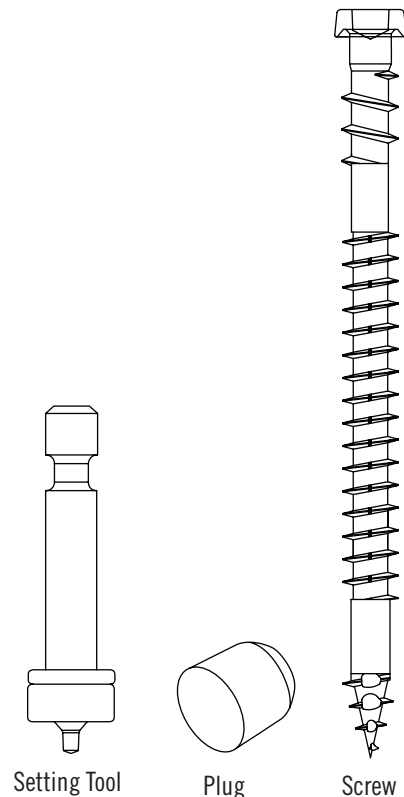

# L-Bracket

Visit [www.timbertech.com/installation](http://www.timbertech.com/installation) to view TimberTech installation videos.

## L-Bracket Installation Instructions

TimberTech L-Bracket Clips are designed for use on the first and last planks when installing TimberTech decking (NOTE: The L-Bracket Clip is not for use with TimberTech ReliaBoard.™) Locate and install one L-Bracket at the start and end of the plank in the corner where the joist meets the rim joist. Then install two clips in every joist bay spaced where  $x = J/2$  and  $y = J/4$  where (J) is the center to center spacing of the joist.

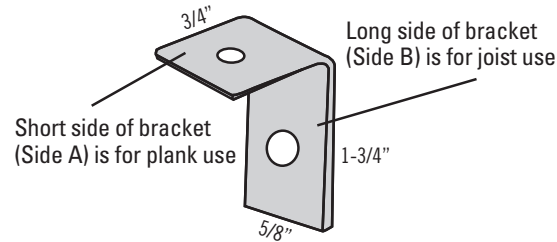

## Clip Space Diagram

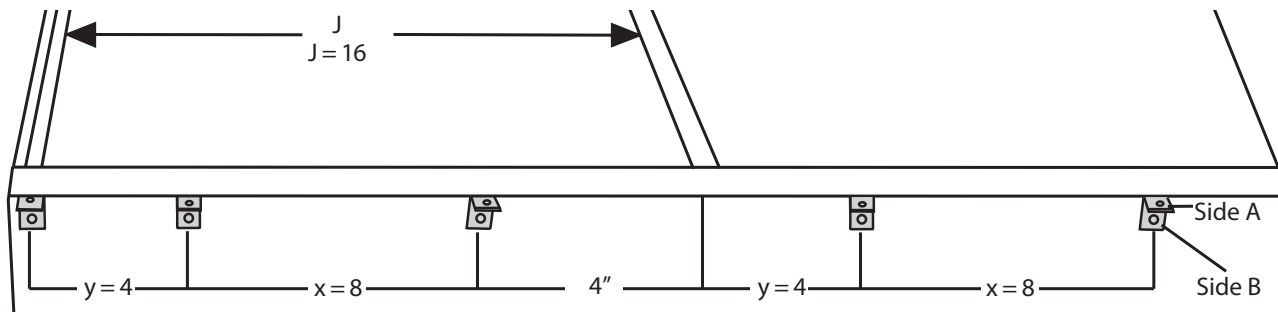

## When Installing on First Plank as a “Start Clip”

TimberTech recommends starting from the outside and working your way towards the house. This way, if the last board needs to be ripped, it will be less visible.

## Option A: Start with the first plank overhanging the rim joist

- 1 Use the 1 1/2" joist screw provided to install the L-Bracket into the outside of the rim joist.

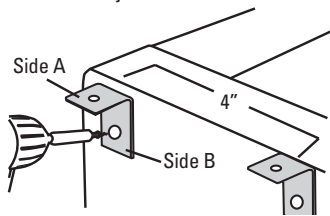

- 2 Then use the 3/4" plank screw to attach the L-Bracket to the plank.

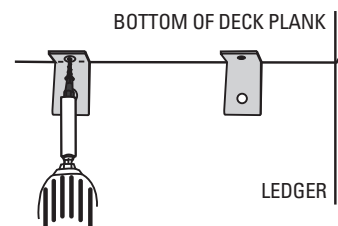

NOTE: Refer to “clip spacing diagram” above for proper clip spacing.



## Option B: Start with the first plank flush with the outside of the rim joist

- 1 Use the 1 1/2" screw provided to install L-Bracket into the inside of rim joist.

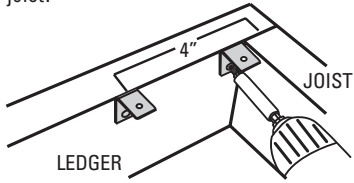

- 2 Use the 3/4" screw to attach the L-Bracket to the underside of the plank.

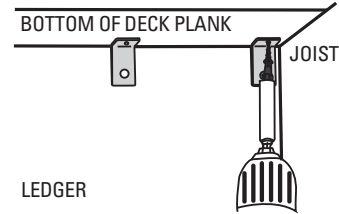

NOTE: Refer to "clip spacing diagram" above for proper clip spacing.

## When Installing on Last Plank as a "Stop Clip"

To use the L-Bracket on the last board, you must have sufficient access to the underside of the deck. This is so you can attach each L-Bracket into the underside of the plank. Once the other planks are installed, you will not be able to access the underside of the last plank from above. In general, you need several feet of clearance from the ground below to get underneath and attach the L-Bracket to the plank. Follow the same installation and spacing instructions as above.

# 25-Year Limited Fade and Stain Warranty

## Earthwood Evolutions decking, fascia, and riser

---

Statement of Warranty: This warranty is given to the original residential purchaser (“Purchaser”), of TimberTech Limited (“TimberTech”) Earthwood Evolutions decking (the “Product”). For purposes of this warranty, a residential Purchaser shall refer to a single-family residential homeowner.

TimberTech warrants to Purchaser that, for a period of twenty-five (25) years from the date of the original consumer purchase (the “Term”), under normal use and service conditions:

(1) The Product’s color will not fade from light and weathering exposure, as measured by a color change of more than 5 Delta E (CIE) units. While the Product is designed to resist fading, no material is fade proof when subjected to years of exposure to ultraviolet (UV) rays and the elements.

(2) The Product will resist permanent staining from food and beverage items that may be spilled onto the surface of the Product, including items such as condiments (barbecue sauce, ketchup, mustard, mayonnaise), salad dressing and salad oils, grease, tea, wine, coffee, fruit punch, sodas and other food and beverage related items that would typically be present on a residential deck, provided that such substances are removed from the Product with soap and water or mild household cleaners after no more than one (1) week of exposure of the substances to the surface of the Product.

Notwithstanding the foregoing, TimberTech does not warrant that the Product is stain-proof, and does not warrant stain resistance resulting from spilled or otherwise applied food and beverage substances which are not properly cleaned as provided above within one (1) week of exposure. In addition, this warranty does not cover any staining or damage to the Product resulting from abrasive compounds of acidic or basic pH, paints or stains, strong solvents, metallic rust or other abnormal residential deck use items, and non-food and non-beverage substances, including, but not limited to, biocides, fungicides, plant foods or other bactericides.

All warranties are subject to the exclusions, limitations and restrictions set forth in the foregoing paragraph and below.

Standard TimberTech 25 Year Limited Residential Warranty. This warranty is in addition to the standard TimberTech Limited 25 Year Limited Residential Warranty that applies to TimberTech alternative decking materials.

Obtaining Warranty Performance: Purchaser must do as follows in order to make a claim under this warranty:

Claims Regarding Stain-Resistance: If the Purchaser is making a claim relating to the warranty on stain resistance, Purchaser must do all of the following (in addition to the procedures set forth below for All Claims):

1. Attempt to clean the affected area of the Product by using the cleaning procedures described above within one (1) week of exposure of the food or beverage to the surface of the Product.
2. If, after completing step 1 above, the affected area remains reasonably unsatisfactory, then Purchaser must have the affected area of the Product cleaned by a professional deck cleaner at Purchaser’s expense.
3. If, after completing steps 1 and 2 above, the affected area still remains reasonably unsatisfactory, Purchaser may make a claim under this warranty as provided herein, provided that such claim is made within thirty (30) days after the professional cleaning is completed.

All Claims: Purchaser, must no later than the end of the Term, send to TimberTech proof of purchase, a description and photographs of the affected area of the Product, and, if the claim relates to the warranty on stain resistance, and reasonable proof of compliance with the requirements set forth above under “Claims Regarding Stain-Resistance,” to the following address:

TimberTech Limited

894 Prairie Avenue

Wilmington, Ohio 45177

Attn: Claims Department

TimberTech reserves the right to request additional information in connection with the warranty claim.

After reviewing all information, TimberTech will make a determination regarding the validity of the claim submitted. If TimberTech determines that the Purchaser’s claim is valid, TimberTech will, at its sole option, either replace the affected item or refund the portion of the purchase price paid by the Purchaser for such affected item (not including the cost of its initial installation). Replacement material will be provided that is as close as possible in color, design and quality as the replaced material, but TimberTech does not guarantee an exact match as colors and design may change.

If Purchaser makes a valid warranty claim hereunder during years eleven (11) through twenty-five (25) after the original purchase, then Purchaser’s recovery will be prorated as indicated below. If TimberTech is providing replacement materials, it may elect to replace the percentage listed below of boards otherwise meeting the requirements for a claim; if TimberTech is refunding the purchase price, it may elect to refund the percentage listed below of the purchase price of boards otherwise meeting the requirements for a claim.

(Continued)

# 25-Year Limited Fade and Stain Warranty (continued)



## Earthwood Evolutions decking, fascia, and riser

<u>Year of Warranty Claim</u>	<u>Percentage Recovery</u>
11	80%
12	80%
13	80%
14	60%
15	60%
16	60%
17	40%
18	40%

<u>Year of Warranty Claim</u>	<u>Percentage Recovery</u>
19	40%
20	20%
21	20%
22	20%
23	10%
24	10%
25	10%

This warranty shall not cover, and TimberTech shall not be responsible for, costs and expenses incurred with respect to the removal of affected Product or the installation of replacement materials, including but not limited to, labor and freight. The foregoing remedies are the SOLE AND EXCLUSIVE REMEDY FOR BREACH OF ANY WARRANTY.

**Transfer of Warranty:** This warranty may be transferred one (1) time, within the five (5) year period beginning from the date of original purchase by Purchaser, to a subsequent buyer of the property upon which the Product was originally installed.

### Exclusions from Warranty Coverage:

TimberTech does not warrant against and is not responsible for, and no implied warranty shall be deemed to cover, any product failure, product malfunction, condition or damages attributable to the following: (1) improper installation of the Product and/or failure to abide by TimberTech's installation guidelines, including but not limited to improper gapping; (2) use of the Product beyond normal residential use, or in an application not recommended by the TimberTech installation guidelines and local building codes; (3) movement, distortion, collapse or settling of the ground or the supporting structure on which the Product is installed; (4) exposure to, or direct or indirect contact with extreme heat sources (over 250 degrees), which may damage the surface of the product and cause the Product to fade; (5) any act of God (such as flooding, hurricane, earthquake, lightning, etc.) or environmental condition (such as air pollution, mold, mildew, etc.), (6) improper handling, storage, abuse or neglect of the Product by Purchaser, the transferee or third parties; (7) any fading or staining not on the surface of the Product (i.e., the underside or the ends of the Product); or (8) ordinary wear and tear.

In addition, this warranty will be voided if (1) paint, stain or other coating materials are applied to the Product, or (2) the surface of the Product has been damaged or punctured, including as a result of contact with shovels or similar sharp-edged tools. Such tools should not be used under any circumstance to remove snow, ice, or other debris from the surface of the product.

Purchaser is solely responsible for determining the effectiveness, fitness, suitability and safety of the Product in connection with its use in any particular application.

**Limitations: DISCLAIMER OF WARRANTIES:** EXCEPT FOR THE EXPRESS WRITTEN WARRANTY CONTAINED HEREIN AND IN THE TIMBERTECH LIMITED 25 YEAR LIMITED RESIDENTIAL WARRANTY, TIMBERTECH MAKES NO OTHER WARRANTIES, GUARANTEES OR INDEMNITIES, WHETHER EXPRESS OR IMPLIED, ARISING BY LAW, COURSE OF DEALING, USAGE OF TRADE, CUSTOM OR OTHERWISE, INCLUDING BUT NOT LIMITED TO THE IMPLIED WARRANTY OF MERCHANTABILITY AND IMPLIED WARRANTY OF FITNESS FOR A PARTICULAR PURPOSE, AND ALL SUCH OTHER WARRANTIES, GUARANTEES AND INDEMNITIES ARE HEREBY DISCLAIMED, OVERRIDDEN AND EXCLUDED FROM THIS TRANSACTION.

Some states do not allow limitations on how long an implied warranty lasts so the above limitation may not apply to you.

**LIMITATION OF REMEDIES AND EXCLUSION OF CONSEQUENTIAL AND INCIDENTAL DAMAGES:** TIMBERTECH'S LIABILITIES ARE LIMITED SOLELY AND EXCLUSIVELY TO THE OBLIGATIONS SPECIFICALLY UNDERTAKEN HEREIN, AND UNDER NO CIRCUMSTANCES WILL TIMBERTECH BE LIABLE OR OBLIGATED FOR ANY INCIDENTAL, CONSEQUENTIAL, INDIRECT, SPECIAL, PUNITIVE OR ANY OTHER DAMAGES OF ANY KIND WHATSOEVER (INCLUDING, BUT NOT LIMITED TO, LOST PROFITS, LOST SALES, LOSS OF GOODWILL, USE OF MONEY, USE OF GOODS, STOPPAGE OF WORK, OR IMPAIRMENT OF ASSETS), WHETHER FORESEEABLE OR UNFORESEEABLE, ARISING OUT OF BREACH OR FAILURE OF EXPRESS OR IMPLIED WARRANTY, BREACH OF CONTRACT, FRAUD, MISREPRESENTATION, NEGLIGENCE, STRICT LIABILITY IN TORT OR OTHERWISE, EXCEPT AND ONLY TO THE EXTENT THIS LIMITATION IS SPECIFICALLY PRECLUDED BY APPLICABLE LAW OF MANDATORY APPLICATION. TIMBERTECH'S LIABILITY WITH RESPECT TO DEFECTIVE PRODUCTS SHALL IN NO EVENT EXCEED THE REPLACEMENT OF SUCH PRODUCTS OR REFUND OF THE PURCHASE PRICE, AS DESCRIBED ABOVE.

Some states do not allow the exclusion or limitation of incidental or consequential damages, so the above limitation or exclusion may not apply to you. This warranty gives you specific legal rights, and you may also have other rights that vary from state to state.

**Miscellaneous:** This writing is understood and intended to be the final expression of the parties' agreement and is a complete and exclusive statement of the terms and conditions with respect thereto, superseding all prior agreements or representations, oral or written, and all other communication between the parties relating to the subject matter of this agreement. This warranty may not be altered or amended except in a written instrument signed by TimberTech and Purchaser or permitted transferee. No agent, employee or any other party is authorized to make any warranty in addition to that made in this agreement and TimberTech shall not be bound by any such statements other than those contained in this warranty.

This warranty is effective for purchases by residential purchasers made on or after January 1, 2011.

Copyright © 2011 TimberTech.

# 25-Year Limited Residential Warranty

## 10-Year Limited Commercial Warranty



### Alternative decking materials, rail systems, accessories and the DrySpace deck drainage system

**Statement of Warranty:** This warranty is given to the original purchaser, residential or commercial as the case may be ("Purchaser"), of TimberTech alternative decking materials, rail systems (excluding all metal baluster components of such rail systems and DeckLites, which are covered under separate warranties), and accessories (individually and collectively "Decking Materials") and the DrySpace deck drainage system ("DrySpace" and, collectively with the Decking Materials, the "TimberTech Products"). This warranty does not extend to fasteners that are not supplied by TimberTech. For purposes of this warranty, a residential Purchaser shall refer to a single-family residential homeowner and a commercial Purchaser shall refer to any Purchaser other than a single-family residential homeowner.

TimberTech Limited ("TimberTech") warrants to Purchaser that, for a period of twenty-five (25) years (Residential) & ten (10) years (Commercial) from the date of the original purchase, residential or commercial as the case may be, (the "Term"), under normal use and service conditions, that: (1) the Decking Materials will be free from material defects in workmanship and materials, and will not check, split, splinter, rot or suffer structural damage from termites or fungal decay; and (2) DrySpace will not peel, blister, pit, flake, crack or corrode as a result of manufacturing defects, or as a result of exposure to ocean air (salt spray).

All warranties are subject to the exclusions, limitations and restrictions set forth below.

**Obtaining Warranty Performance:** If Purchaser discovers a defect in the TimberTech Products during the Term, Purchaser must, within thirty (30) days from the discovery of the alleged defect but **no later than the end of the Term**, notify TimberTech in writing, at the following address:

TimberTech Limited  
894 Prairie Avenue  
Wilmington, Ohio 45177  
Attn: Claims Department

Purchaser must include in this notification proof of purchase and a statement explaining the defect. TimberTech may request additional information. After reviewing all information, TimberTech will make a determination regarding the validity of such claim. If TimberTech determines that Purchaser's claim is valid, TimberTech will, at its option, either replace the defective TimberTech Products or refund the portion of the purchase price paid by Purchaser for such defective TimberTech Products (not including the cost of its initial installation).

If a residential Purchaser makes a valid warranty claim hereunder during years eleven (11) through twenty-five (25) after the original purchase, then the residential Purchaser's recovery will be prorated as indicated below. If TimberTech is providing replacement materials, it may elect to replace the percentage listed below of boards otherwise meeting the requirements for a claim; if TimberTech is refunding the purchase price, it may elect to refund the percentage listed below of the purchase price of boards otherwise meeting the requirements for a claim.

Year of Claim	Recovery
11	80%
12	80%
13	80%
14	60%
15	60%

Year of Claim	Recovery
16	60%
17	40%
18	40%
19	40%
20	20%

Year of Claim	Recovery
21	20%
22	20%
23	10%
24	10%
25	10%

This warranty shall not cover, and TimberTech shall not be responsible for, costs and expenses incurred with respect to the removal of the defective TimberTech Products or the installation of replacement materials, including but not limited to, labor and freight. The foregoing remedies are the **SOLE AND EXCLUSIVE REMEDY FOR BREACH OF ANY WARRANTY**.

**Transfer of Warranty:** This warranty may be transferred one (1) time, within the five (5) year period beginning from the date of original purchase by Purchaser, to a subsequent buyer of the property upon which the TimberTech Products were originally installed.

**Exclusions from Warranty Coverage:** TimberTech does not warrant against and is not responsible for, and no implied warranty shall be deemed to cover, any product failure, product malfunction, or damages attributable to: (1) improper installation of the TimberTech Products and/or failure to abide by TimberTech's installation guidelines, including but not limited to improper gapping; (2) use of TimberTech Products beyond normal use, or in an application not recommended by the TimberTech installation guidelines and local building codes; (3) movement, distortion, collapse or settling of the ground or the supporting structure on which the TimberTech Products are installed; (4) any act of God (such as flooding, hurricane, earthquake, lightning, etc.), environmental condition (such as air pollution, mold, mildew, etc.), or staining from foreign substances (such as dirt, grease, oil, etc.); (5) variations or changes in color of TimberTech Products; (6) normal weathering due to exposure to sunlight, weather and atmosphere which can cause colored surfaces to, among other things, flake, chalk, or accumulate dirt or stains; (7) improper handling, storage, abuse or neglect of the TimberTech Products by Purchaser, the transferee or third parties; (8) any fasteners not supplied by TimberTech; or (9) minor dripping from DrySpace.

Purchaser is solely responsible for determining the effectiveness, fitness, suitability and safety of the TimberTech Products in connection with their use in any particular application.

**Limitations: DISCLAIMER OF WARRANTIES:** EXCEPT FOR (1) THE EXPRESS WRITTEN WARRANTY CONTAINED HEREIN, AND, (2) THE 25 YEAR LIMITED RESIDENTIAL FADE AND STAIN WARRANTY APPLICABLE TO EARTHWOOD EVOLUTIONS DECKING ONLY (WHICH IS IN ADDITION TO THE WARRANTY CONTAINED HEREIN), TIMBERTECH MAKES NO OTHER WARRANTIES, GUARANTEES OR INDEMNITIES, WHETHER EXPRESS OR IMPLIED, ARISING BY LAW, COURSE OF DEALING, USAGE OF TRADE, CUSTOM OR OTHERWISE, INCLUDING BUT NOT LIMITED TO THE IMPLIED WARRANTY OF MERCHANTABILITY AND IMPLIED WARRANTY OF FITNESS FOR A PARTICULAR PURPOSE, AND ALL SUCH OTHER WARRANTIES, GUARANTEES AND INDEMNITIES ARE HEREBY DISCLAIMED, OVERRIDDEN AND EXCLUDED FROM THIS TRANSACTION FOR THE WARRANTY TERM AND BEYOND THE WARRANTY TERM.

Some states do not allow limitations on how long an implied warranty lasts so the above limitation may not apply to you.

**LIMITATION OF REMEDIES AND EXCLUSION OF CONSEQUENTIAL AND INCIDENTAL DAMAGES:** TIMBERTECH'S LIABILITIES ARE LIMITED SOLELY AND EXCLUSIVELY TO THE OBLIGATIONS SPECIFICALLY UNDERTAKEN HEREIN, AND UNDER NO CIRCUMSTANCES WILL TIMBERTECH BE LIABLE OR OBLIGATED FOR ANY INCIDENTAL, CONSEQUENTIAL, INDIRECT, SPECIAL, PUNITIVE OR ANY OTHER DAMAGES OF ANY KIND WHATSOEVER (INCLUDING, BUT NOT LIMITED TO, LOST PROFITS, LOST SALES, LOSS OF GOODWILL, USE OF MONEY, USE OF GOODS, STOPPAGE OF WORK, OR IMPAIRMENT OF ASSETS), WHETHER FORESEEABLE OR UNFORESEEABLE, ARISING OUT OF BREACH OR FAILURE OF EXPRESS OR IMPLIED WARRANTY, BREACH OF CONTRACT, FRAUD, MISREPRESENTATION, NEGLIGENCE, STRICT LIABILITY IN TORT OR OTHERWISE, EXCEPT AND ONLY TO THE EXTENT THIS LIMITATION IS SPECIFICALLY PRECLUDED BY APPLICABLE LAW OF MANDATORY APPLICATION. TIMBERTECH'S LIABILITY WITH RESPECT TO DEFECTIVE PRODUCTS SHALL IN NO EVENT EXCEED THE REPLACEMENT OF SUCH PRODUCTS OR REFUND OF THE PURCHASE PRICE, AS DESCRIBED ABOVE.

Some states do not allow the exclusion or limitation of incidental or consequential damages, so the above limitation or exclusion may not apply to you. This warranty gives you specific legal rights, and you may also have other rights that vary from state to state.

**Miscellaneous:** This writing is understood and intended to be the final expression of the parties' agreement and is a complete and exclusive statement of the terms and conditions with respect thereto, superseding all prior agreements or representations, oral or written, and all other communication between the parties relating to the subject matter of this agreement. This warranty may not be altered or amended except in a written instrument signed by TimberTech and Purchaser or permitted transferee. No agent, employee or any other party is authorized to make any warranty in addition to that made in this agreement and TimberTech shall not be bound by any such statements other than those contained in this warranty.

This warranty shall only be applicable and enforceable in the United States of America.

This warranty is effective for purchases (residential or commercial, as the case may be) made on or after January 1, 2011.

Copyright (c) 2011 TimberTech.

# TOPLoc™ 25-Year Residential Warranty Against Corrosion

## TOPLoc™ 10-Year Commercial Warranty Against Corrosion

### TOPLoc Fascia and Face Fastening

---

**Statement of Warranty:** This warranty is given to the original purchaser, residential or commercial as the case may be ("Purchaser"), of TimberTech TOPLoc™ exterior (i) ACQ Rated and Composite screws, and (ii) stainless steel screws (collectively, the "TOPLoc™ Screws"). For purposes of this warranty, a residential Purchaser shall refer to a single-family residential homeowner and a commercial Purchaser shall refer to any Purchaser other than a single-family residential homeowner.

TimberTech Limited ("TimberTech") warrants to Purchaser that, for a period of twenty-five (25) years (Residential) & ten (10) years (Commercial) from the date of the original purchase, residential or commercial as the case may be, (the "Term"), under normal use and service conditions, that the TOPLoc™ Screws will not corrode due to exposure to (i) normal environmental conditions, or (ii) corrosives contained in natural wood species, treated lumber, or plastic/wood composite decking material, or (iii) to exposure to chemicals used, as of January 1, 2007, in pressure treated lumber formulations designated as, ACQ, MCQ, Copper Quat, or Copper Azole types CBA-A and CA-B; provided, however, that TOPLoc™ ACQ Rated and Composite screws are not warranted for use on or near the water, including but not limited to, applications such as docks, boardwalks or piers (only TOPLoc™ stainless steel Screws are warranted for such applications).

All warranties are subject to the additional exclusions, limitations and restrictions set forth below.

**Obtaining Warranty Performance:** If Purchaser discovers a defect in the TOPLoc™ Screws during the Term, Purchaser must, within thirty (30) days from the discovery of the alleged defect but no later than the end of the Term, notify TimberTech in writing, at the following address:

TimberTech Limited  
894 Prairie Avenue  
Wilmington, Ohio 45177  
Attn: Claims Department

Purchaser must include in this notification proof of purchase and a statement explaining the defect. TimberTech may request additional information. After reviewing all information, TimberTech will make a determination regarding the validity of such claim. For any claim that TimberTech determines to be valid, TimberTech will replace the defective TOPLoc™ Screws. It is the sole responsibility of Purchaser to arrange and to pay for the return to TimberTech of any TOPLoc™ Screws to which this warranty applies.

This warranty shall not cover, and TimberTech shall not be responsible for, costs and expenses incurred with respect to the removal of the defective TOPLoc™ Screws or the installation of replacement materials, including but not limited to, labor and freight. The foregoing remedy is the SOLE AND EXCLUSIVE REMEDY FOR BREACH OF ANY WARRANTY.

**Transfer of Warranty:** This warranty may be transferred one (1) time, within the five (5) year period beginning from the date of original purchase by Purchaser, to a subsequent buyer of the property upon which the TOPLoc™ Screws were originally installed.

**Exclusions from Warranty Coverage:** TimberTech does not warrant against and is not responsible for, and no implied warranty shall be deemed to cover, any product failure, product malfunction, or damages attributable to: (1) improper installation of the TOPLoc™ Screws and/or failure to abide by TimberTech's installation guidelines; or (2) use of TOPLoc™ Screws beyond normal use, or in an application not recommended by the TimberTech installation guidelines and local building codes.

Purchaser is solely responsible for determining the effectiveness, fitness, suitability and safety of the TOPLoc™ Screws in connection with their use in any particular application.

**ALL IMPLIED WARRANTIES, INCLUDING BUT NOT LIMITED TO THE IMPLIED WARRANTY OF MERCHANTABILITY AND IMPLIED WARRANTY OF FITNESS FOR A PARTICULAR PURPOSE, ARE LIMITED IN DURATION TO THE TWENTY-FIVE YEAR DURATION OF THE RESIDENTIAL LIMITED WARRANTY AND ARE DISCLAIMED FOR ALL PERIODS THEREAFTER.**

**Limitations: DISCLAIMER OF WARRANTIES (RESIDENTIAL PURCHASER):** EXCEPT FOR THE EXPRESS WRITTEN WARRANTY CONTAINED HEREIN, TIMBERTECH MAKES NO OTHER EXPRESS WARRANTIES, GUARANTEES OR INDEMNITIES, ARISING BY COURSE OF DEALING, USAGE OF TRADE OR CUSTOM, AND ALL SUCH OTHER EXPRESS WARRANTIES, GUARANTEES AND INDEMNITIES ARE HEREBY DISCLAIMED, OVERRIDDEN AND EXCLUDED FROM THIS TRANSACTION FOR THE WARRANTY TERM AND BEYOND THE WARRANTY TERM.

**Limitations: DISCLAIMER OF WARRANTIES (COMMERCIAL PURCHASERS):** EXCEPT FOR THE EXPRESS WRITTEN WARRANTY CONTAINED HEREIN, TIMBERTECH MAKES NO OTHER WARRANTIES, GUARANTEES OR INDEMNITIES, WHETHER EXPRESS OR IMPLIED, ARISING BY LAW, COURSE OF DEALING, USAGE OF TRADE, CUSTOM OR OTHERWISE, INCLUDING BUT NOT LIMITED TO THE IMPLIED WARRANTY OF MERCHANTABILITY AND IMPLIED WARRANTY OF FITNESS FOR A PARTICULAR PURPOSE, AND ALL SUCH OTHER WARRANTIES, GUARANTEES AND INDEMNITIES ARE HEREBY DISCLAIMED, OVERRIDDEN AND EXCLUDED FROM THIS TRANSACTION FOR THE WARRANTY TERM AND BEYOND THE WARRANTY TERM.

Some states do not allow limitations on how long an implied warranty lasts so the above limitation may not apply to you.

**LIMITATION OF REMEDIES AND EXCLUSION OF CONSEQUENTIAL AND INCIDENTAL DAMAGES:** TIMBERTECH'S LIABILITIES ARE LIMITED SOLELY AND EXCLUSIVELY TO THE OBLIGATIONS SPECIFICALLY UNDERTAKEN HEREIN, AND UNDER NO CIRCUMSTANCES WILL TIMBERTECH BE LIABLE OR OBLIGATED FOR ANY INCIDENTAL, CONSEQUENTIAL, INDIRECT, SPECIAL, PUNITIVE OR ANY OTHER DAMAGES OF ANY KIND WHATSOEVER (INCLUDING, BUT NOT LIMITED TO, LOST PROFITS, LOST SALES, LOSS OF GOODWILL, USE OF MONEY, USE OF GOODS, STOPPAGE OF WORK, OR IMPAIRMENT OF ASSETS), WHETHER FORESEEABLE OR UNFORESEEABLE, ARISING OUT OF BREACH OR FAILURE OF EXPRESS OR IMPLIED WARRANTY, BREACH OF CONTRACT, FRAUD, MISREPRESENTATION, NEGLIGENCE, STRICT LIABILITY IN TORT OR OTHERWISE, EXCEPT AND ONLY TO THE EXTENT THIS LIMITATION IS SPECIFICALLY PRECLUDED BY APPLICABLE LAW OF MANDATORY APPLICATION. TIMBERTECH'S LIABILITY WITH RESPECT TO DEFECTIVE PRODUCTS SHALL IN NO EVENT EXCEED THE REPLACEMENT OF SUCH PRODUCTS, AS DESCRIBED ABOVE.

Some states do not allow the exclusion or limitation of incidental or consequential damages, so the above limitation or exclusion may not apply to you. This warranty gives you specific legal rights, and you may also have other rights that vary from state to state.

**Miscellaneous:** This writing is understood and intended to be the final expression of the parties' agreement and is a complete and exclusive statement of the terms and conditions with respect thereto, superseding all prior agreements or representations, oral or written, and all other communication between the parties relating to the subject matter of this agreement. This warranty may not be altered or amended except in a written instrument signed by TimberTech and Purchaser or permitted transferee. No agent, employee or any other party is authorized to make any warranty in addition to that made in this agreement and TimberTech shall not be bound by any such statements other than those contained in this warranty.

This warranty is effective for purchases (Residential or Commercial, as the case may be) made on or after January 1, 2011.

Copyright (c) 2011 TimberTech.

**Every TimberTech product is backed by exceptional customer service and a commitment to quality.**

**Decking, Railing & Fencing** — TimberTech decking, railing and fencing products are backed by a 25-year limited warranty for residential applications and a 10-year limited warranty for commercial applications.\*

TimberTech products are guaranteed against: • Termites • Decay • Checking • Rotting • Splitting • Splintering

\* This does not include BuilderRail metal balusters which are covered by a 10-year limited warranty against cracking, peeling, blistering, and corrosion.

**DeckLites** — TimberTech DeckLites are covered by a 5-year limited warranty for residential applications.

**DrySpace** — TimberTech DrySpace has a 25-year residential limited warranty on products purchased on or after January 1, 2007. DrySpace products purchased prior to this date have a 5-year limited warranty.

**To Make a Claim** — To make a claim under either warranty, purchaser or the transferee, must send to TimberTech, within the warranty period referred to above, a description of the claimed defect and proof of purchase. Warranty Information Packets can be obtained from TimberTech.

**TimberTech Limited** • Attn: Claims Department  
894 Prairie Avenue, Wilmington, Ohio 45177 Or call 1-800-307-7780

**For a copy of TimberTech's complete warranty visit [www.timbertech.com](http://www.timbertech.com).**

**Warranty Registration is Easy**

- The easiest way to register a warranty is to visit [www.timbertech.com](http://www.timbertech.com) and select the Warranty & Care link, then select Register Online.
- You may prefer to fill out the Warranty Card below and mail it to TimberTech, accordingly to the instructions on the card.

**Remember, to ensure your product is covered by the TimberTech Warranty it must be installed properly.**

TimberTech LTD disclaims any liability or responsibility for the improper installation of this product. The purchaser is solely responsible for compliance with applicable local codes as to the deck's intended use. TimberTech recommends all designs be reviewed by a licensed architect, engineer or local building official before installation. TimberTech maintains a list of physical properties to assist the design professional.

Below is a chart showing which product each warranty covers. You can view warranty details online at [www.timbertech.com](http://www.timbertech.com):

**Limited 25-Year Residential Warranty / Limited 10-Year Commercial Warranty**

**Decking:** DockSider, Floorizon, Earthwood Evolutions, TwinFinish, XLM

**Railing:** Ornamental Rail, RadianceRail, BuilderRail (excluding all metal baluster components of BuilderRail System)

**Fencing:** All FenceScape a products

**Accessories:** CONCEALoc, DrySpace

**Limited 10-Year Warranty for Metal Baluster Components of BuilderRail System**

**Limited 5-Year Warranty for DeckLites System**

**TimberTech Customer:  
Please complete this warranty card and mail to:**

TimberTech  
894 Prairie Avenue  
Wilmington, Ohio 45177  
Attn: Warranty

**This information will help us better serve your needs.**  
Please return warranty card within 30 days of receipt of product.



Name: \_\_\_\_\_ Purchase Date: \_\_\_\_\_  
Street Address: \_\_\_\_\_  
City: \_\_\_\_\_ State/Province: \_\_\_\_\_ Zip/Postal Code: \_\_\_\_\_  
Country: \_\_\_\_\_ Phone: \_\_\_\_\_

**Product Information:**

Where was your product purchased? \_\_\_\_\_  
How was your product installed? \_\_\_\_\_  
 Contractor Name: \_\_\_\_\_  Self-Installed

**Warranty Registration: Check the TimberTech product that you purchased:**

**Decking:**  Earthwood Evolutions™ Plank  ReliaBoard™ Plank  Accessories: \_\_\_\_\_  
 Floorizon® Plank  XLM® Plank \_\_\_\_\_  
 DockSider™ Plank  TwinFinish® Plank

**Railing:**  RadianceRail®  RadianceRail® Express  Ornamental Rail  BuilderRail®  Evolutions™ Rail  
 Metal Balusters  Secure-Mount System  ADA Hand Rail System  CableRail

DrySpace™  DeckLites®  FenceScape®

**Demographic Information:** Number of residents in household: \_\_\_\_\_

Number of household residents in the following age groups:  
 0-12  13-18  19-27  28-39  40-55  55+

Average household income:  
 Under \$35,000  \$35,000-50,000  \$50,000-70,000  \$70,000-95,000  \$95,000+

It's not just a deck. It's TimberTech.



Visit [timbertech.com](http://timbertech.com) or  
call 1-800-307-7780 for more information.