

Evolutions Rail™ Builder Style Installation Guide



Installing Evolutions Rail™ Builder Style with Metal Balusters	2
Installing Evolutions Rail™ Builder Style Stairs with Metal Balusters	7
Installing Evolutions Rail™ Builder Style with Glass Infill.....	12
Installing Evolutions Rail™ Builder Style Stairs with Glass Infill	19
Notes	25

TimberTech Code Listings

Once a product is tested by an independent lab, an application and report is submitted to one of several agencies that provide listings for building products that meet the requirements of Acceptance Criteria 174 (AC 174) as set forth by the International Code Council Evaluation Service (ICC-ES). TimberTech currently has listings from the ICC-ES and Architectural Testing Inc. The following TimberTech reports on code compliance are available to download on www.timbertech.com.

For the most up-to-date code listings visit
www.timbertech.com/installation.

ATI Architectural Testing, Inc.
CCRR-0196 • Evolutions Rail



- Please read all instructions completely before starting any part of the installation.
- TimberTech Rail should be installed using the same good building principles used to install wood or composite railing and in accordance with the local building codes and the installation guidelines included below. TimberTech accepts no liability or responsibility for the improper installation of this product.
- TimberTech Rail may not be suitable for every application and it is the sole responsibility of the installer to be sure that TimberTech Rail is fit for the intended use. Since all installations are unique, it is also the installer's responsibility to determine specific requirements in regards to each Rail application.
- TimberTech recommends that all applications be reviewed by a licensed architect, engineer or local building official before installation. If you have any questions or need further assistance, please call TimberTech Customer Service at 1.800.307.7780 or visit our website at www.timbertech.com.
- TimberTech Railing is tested as a whole system and should be used that way. It is not intended to be used in conjunction with other railing systems or fasteners.
- The following Installation Guidelines are applicable for installation of TimberTech Evolutions Rail Builder Style railing.
- **IMPORTANT:** Make sure the DRIVE TOOL/DRILL is configured or set to use the SCREW setting when driving and/or tightening all FASTENERS.
- **SAFETY:** Always wear goggles when handling, cutting, drilling and fastening materials.
- Failure to install this product in accordance with applicable building codes and TimberTech's written Rail Install Guide may lead to personal injury, affect rail system performance and void the product warranty.

Installing Evolutions Rail™ Builder Style with Metal Balusters



Visit www.timbertech.com/installation to view TimberTech installation videos. Consult your local building codes for guard and handrail requirements.

Evolutions Rail™ BuilderBoards are available in 6' or 8' lengths.

Measuring Your Railing Area

Measurements are from center of post. BuilderBoard is produced to 6' and 8' to allow for finished end cuts and angles.
Determine how many 6' or 8' BuilderBoard sections you need and check to be sure you have all the components (and quantities) listed in the chart shown to the right.

Important Information

- ⚠️ • 6' and 8' BuilderBoard is designed not to exceed 6' and 8' center of post to center of post, respectively
- Cut slowly, using a fine tooth saw blade to avoid chipping.
- For 42" railing, use 8' Post Sleeves.

Component Dimensions

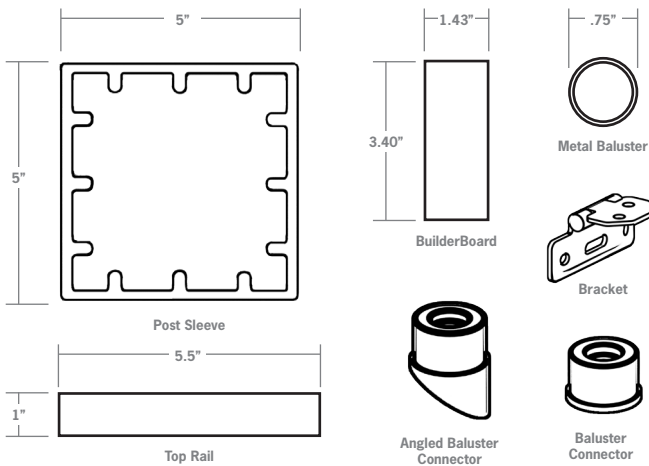

Components Needed For Installing One Builder Style Rail Section				
Components needed to complete rail sections	2 - Post Sleeves 2 - BuilderBoards 2 - Post Skirts 1 - Deck Plank for Top Rail TimberTech TOPLoc Face Fasteners Foot Blocks (2 for 6' Section, 3 for 8' Section) Metal Baluster Pack Hardware Kit End Coating (Optional)			
Components available separately for mix-and-match rail systems	<table border="1"> <tr> <td rowspan="2" style="writing-mode: vertical-rl; transform: rotate(180deg);">Metal Baluster Pack</td> <td> Metal Baluster Pack: 20 Metal Balusters 36" - 25" Height 42" - 31" Height 36" Stair - 23.75" Height 42" Stair - 29.75" Height </td> </tr> <tr> <td> Baluster Connector Packs: 40 - Baluster Connectors 40 - #10 x 2" Screws </td> </tr> </table>	Metal Baluster Pack	Metal Baluster Pack: 20 Metal Balusters 36" - 25" Height 42" - 31" Height 36" Stair - 23.75" Height 42" Stair - 29.75" Height	Baluster Connector Packs: 40 - Baluster Connectors 40 - #10 x 2" Screws
Metal Baluster Pack	Metal Baluster Pack: 20 Metal Balusters 36" - 25" Height 42" - 31" Height 36" Stair - 23.75" Height 42" Stair - 29.75" Height			
	Baluster Connector Packs: 40 - Baluster Connectors 40 - #10 x 2" Screws			
Hardware needed to complete 6' and 8' rail sections	<table border="1"> <tr> <td rowspan="2" style="writing-mode: vertical-rl; transform: rotate(180deg);">Hardware Mounting Kit:</td> <td> 4 - Hinged Brackets 11 - #10 x 2" Screws 8 - #10 x 7/8" Screws 4 - #10 x 1.5" Screws 1 - T-25 </td> </tr> </table>	Hardware Mounting Kit:	4 - Hinged Brackets 11 - #10 x 2" Screws 8 - #10 x 7/8" Screws 4 - #10 x 1.5" Screws 1 - T-25	
Hardware Mounting Kit:	4 - Hinged Brackets 11 - #10 x 2" Screws 8 - #10 x 7/8" Screws 4 - #10 x 1.5" Screws 1 - T-25			

Tools Required

- Miter Saw
- Drill
- Drill Bits: 9/64", 3/16", & 1/2"
- Tape Measure

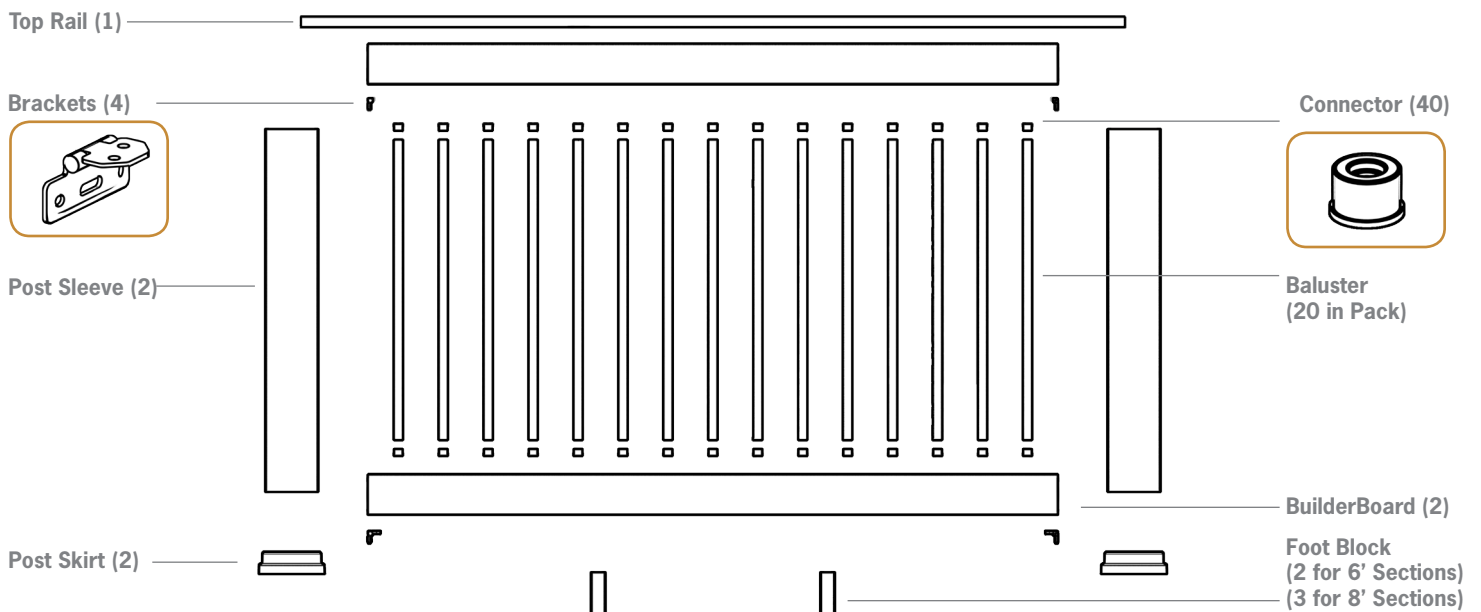

1

CUT POSTS AND TEMPORARILY INSTALL POST SLEEVES

- Posts must be positioned no more than 8' on center, and must be plumb.
- Trim 4x4 Post to a min of 35 1/2" (for 36") and 41 1/4" (for 42) above finished deck surface.
- Slide uncut Post Sleeves over 4x4 posts. Do not force.

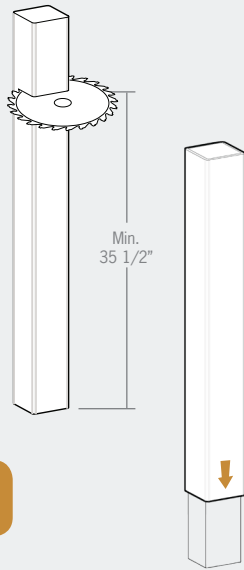

Do not cut Post Sleeves in this step.

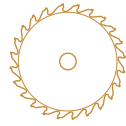

2

MARK BALUSTER LOCATIONS

- Using provided template, mark Baluster locations on one BuilderBoard, then transfer to the other.

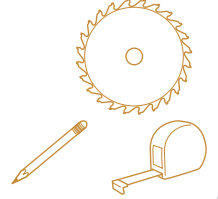
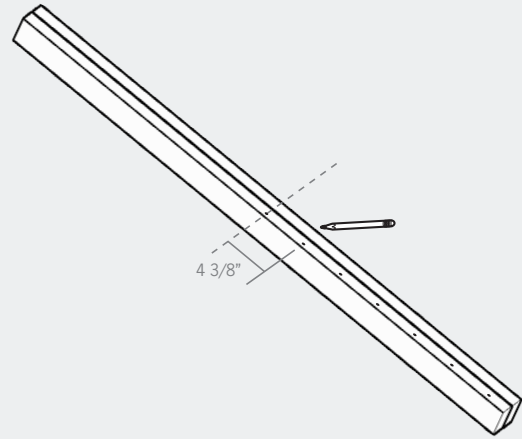

3

MEASURE AND TRIM BUILDERBOARDS

- Measure between Posts.
- Determine if a space or Baluster will be on center.
- Cut BuilderBoards to length.

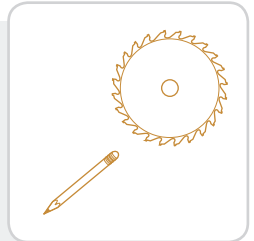
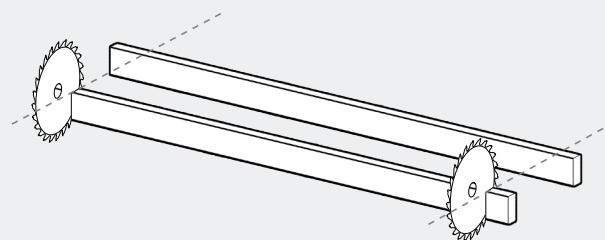
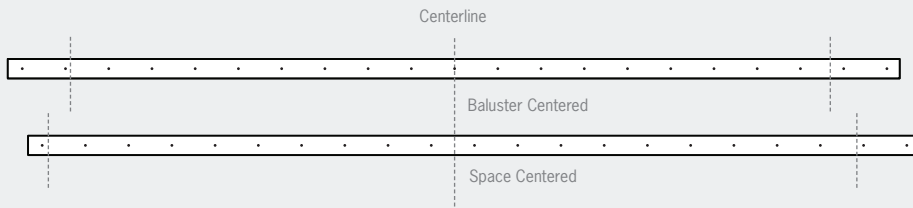
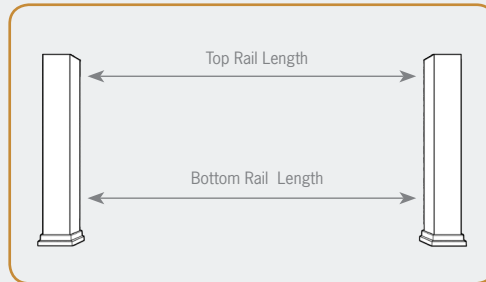

4 ATTACH BALUSTER CONNECTORS, HINGE BRACKETS, AND FOOT BLOCKS

- Pre-Drill 9/64" holes at Baluster marks roughly 2" deep.

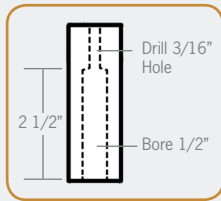

Foot Block Preparation

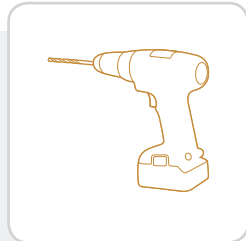
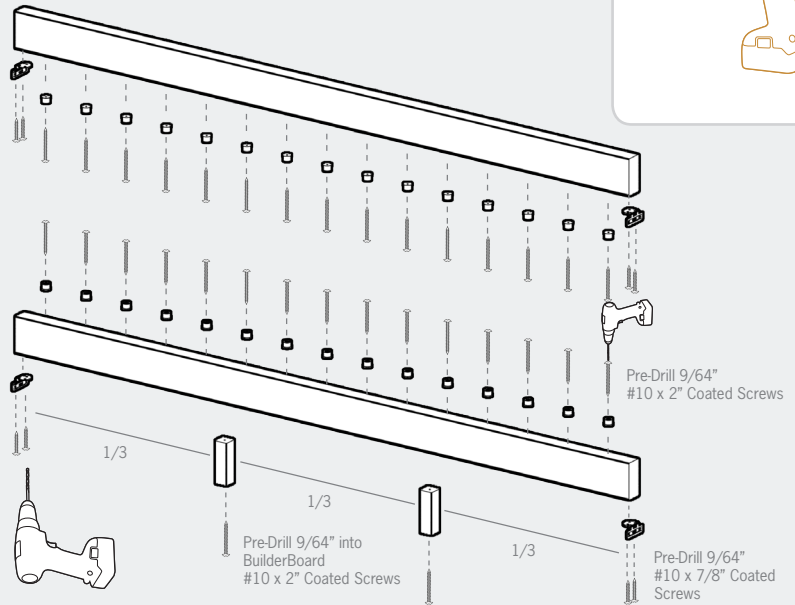

For sections up to 6': Place two Foot Blocks at 1/3 intervals on the rail.
For sections 6' to 8': Space three Foot Blocks approximately at 1/4 intervals on the rail.

5 MEASURE AND TRIM POST SLEEVES

- Temporarily set bottom BuilderBoard in place and install a Baluster on each end. Place top BuilderBoard on top of the Balusters.
- Mark the top of the top BuilderBoard on the Post Sleeves.

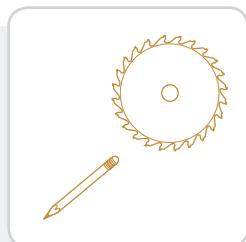
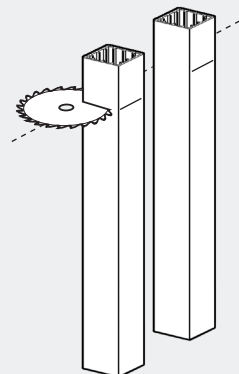
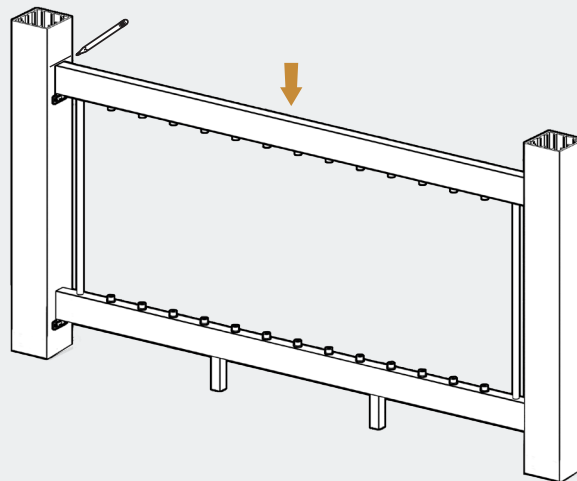

Post Sleeves should be flush with the Top BuilderBoard.

- Slide Post Sleeves off Posts and cut to appropriate length.

6

INSTALL BOTTOM RAIL AND BALUSTERS

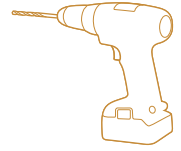

- Replace Post Sleeves and Skirts.
- Install Bottom BuilderBoard by Pre-Drilling through Brackets with 9/64" bit and screwing them to Posts.

Screws are designed to go in at a slight angle.

- Place all Balusters on Baluster Connectors.

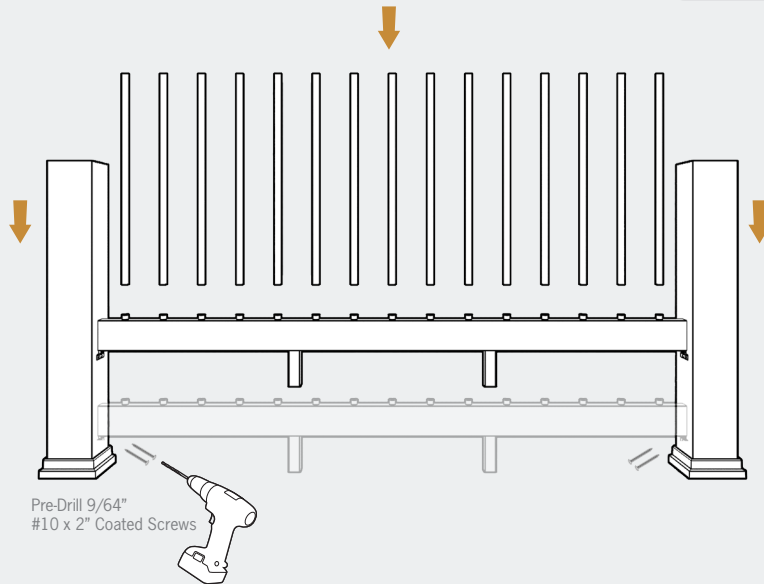

7

INSTALL TOP BUILDERBOARD

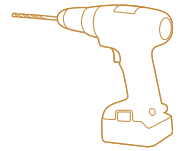

- Place Top BuilderBoard on Balusters.

Start at one end with the top rail angled upward. Work your way down the rail by aligning and lowering the top rail onto each Baluster.

- Make sure Balusters are all snugly seated on Baluster Connectors, then Pre-Drill and secure Top BuilderBoard with Brackets.

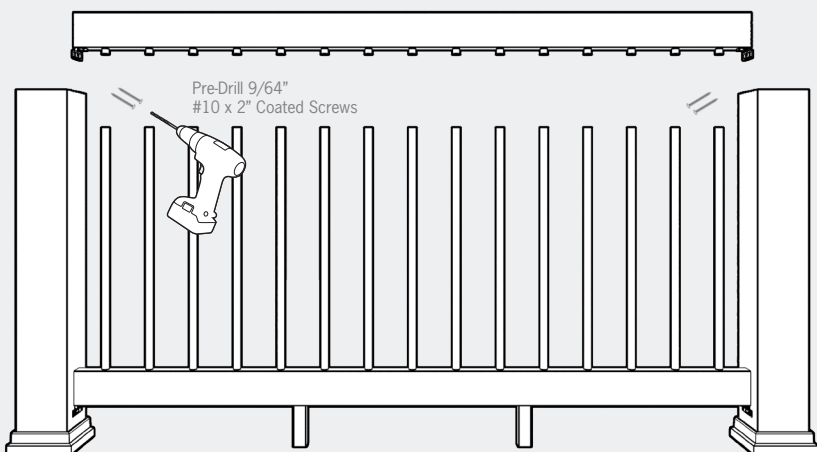

8

INSTALL TOP RAILS

- Cut Planking so that any seams fall at the center of a post. Miter the planks at corner posts.

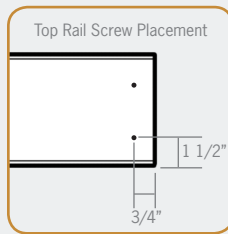
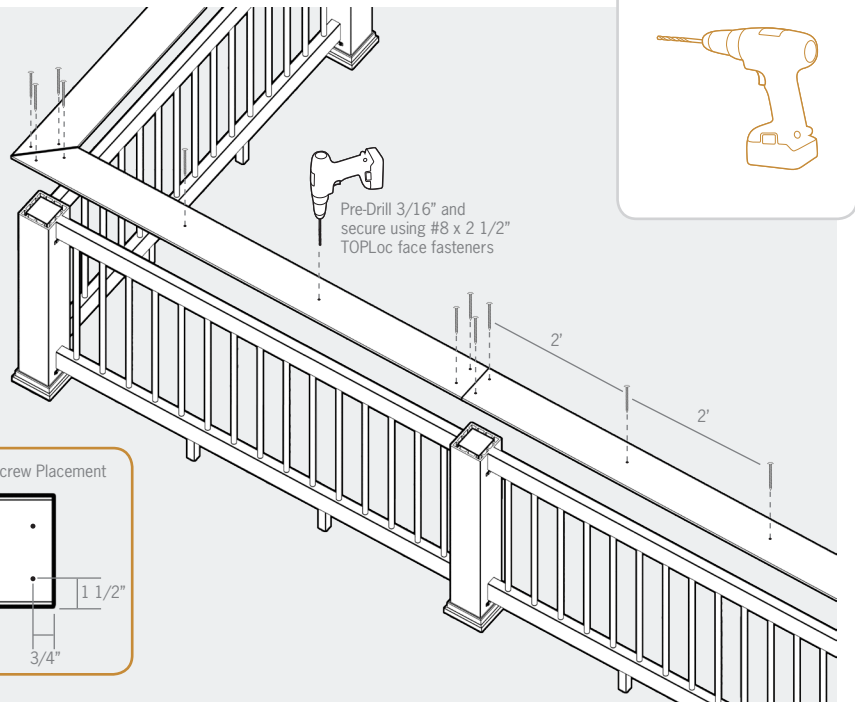

If your rail has stair sections, start installing the cap at the stairs. Wait until all rail sections are complete before beginning Top Rail installation.

1

CUT POSTS AND TEMPORARILY INSTALL POST SLEEVES

- Trim post a min of 35 1/2" (for 36") or 41 1/2" (for 42") above finished deck surface.
- Slide Post Sleeve over 4x4 Post. Do not force.
- Posts may need to be slightly taller for stairs.

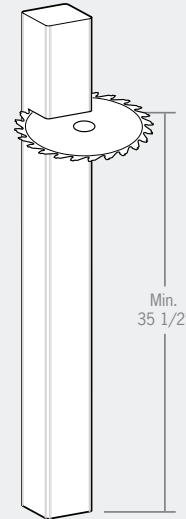
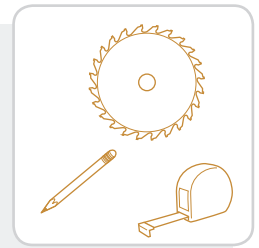
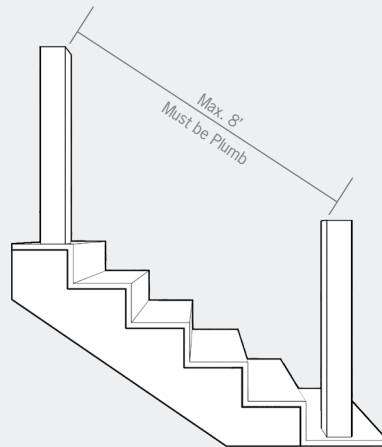

 Do not cut Post Sleeves in this step.

2

MEASURE AND TRIM BUILDERBOARDS

- Position a BuilderBoard on the stairs against the Top and Bottom Post Sleeves.
- Mark the length and angle at each post.
- Trim the ends of the BuilderBoard. Check the fit at Top and Bottom Rail locations, then trim a duplicate BuilderBoard for the Top Rail.

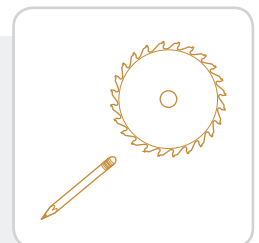
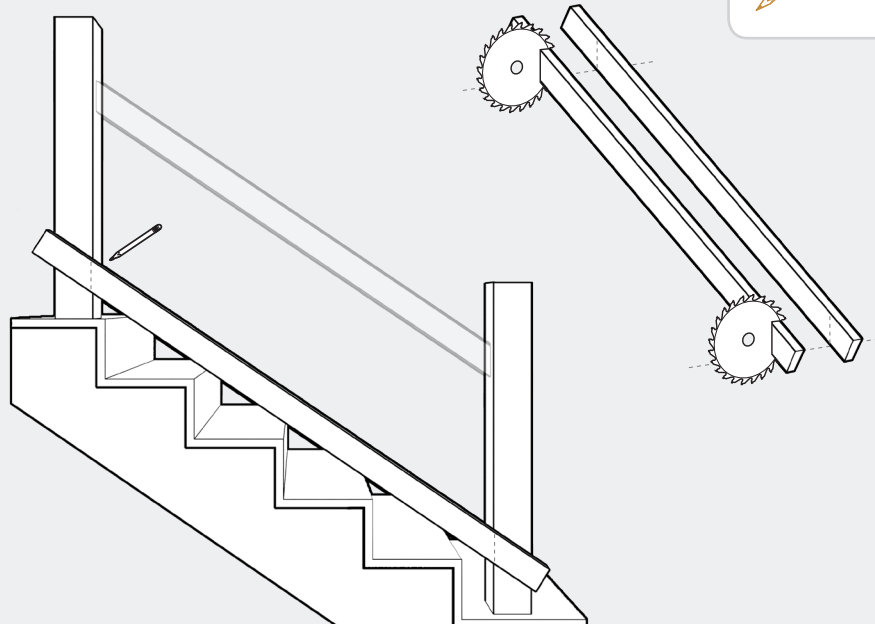

3

DETERMINE METAL BALUSTER LOCATIONS

- Lay trimmed BuilderBoards side by side oriented as shown.

Clamping boards together will make transferring locations much easier.

- Determine if a space or Baluster should be on center.
- Using template provided, mark the Baluster positions on the BuilderBoard Rail.

Stair metal Balusters should be spaced at 5.5".

- Transfer Baluster marks to second BuilderBoard.

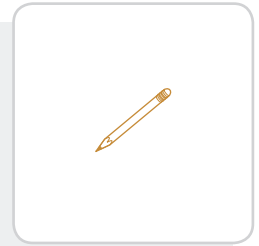
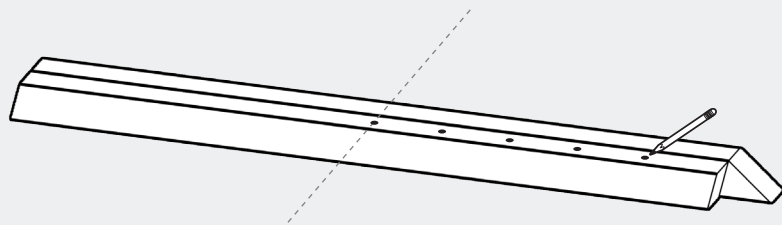
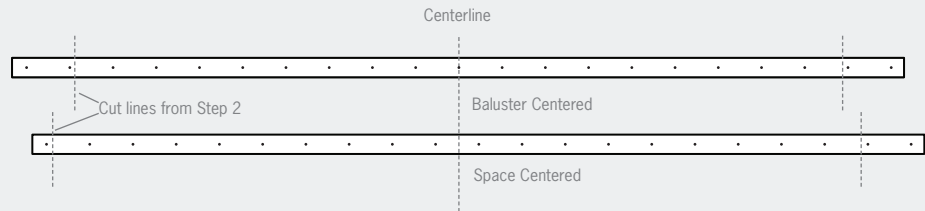

4

ATTACH BALUSTER CONNECTORS AND HINGE BRACKETS

- Pre-Drill holes roughly 2" deep for angled Baluster Connectors using a 9/64" bit and either a Baluster Connector or piece of scrap cut to the stair angle as a drill guide.
- Attach Baluster Connectors.
- Pre-Drill holes for Brackets using them as guides with a 9/64" bit.
- Attach Brackets.

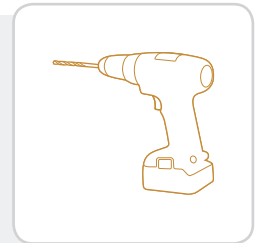
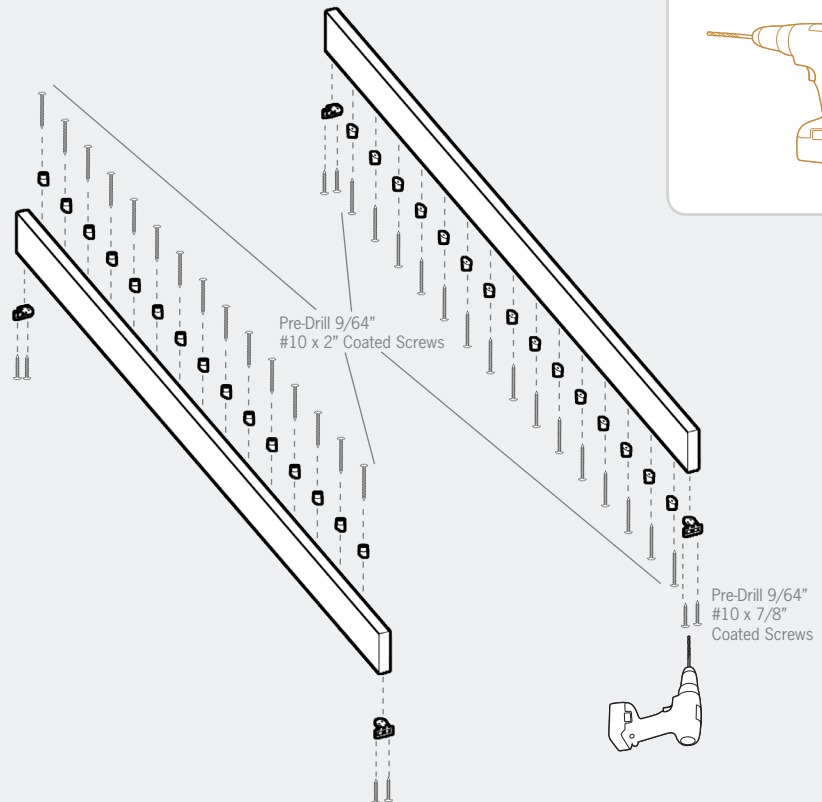

5 INSTALL FOOT BLOCKS

- Temporarily install Bottom BuilderBoard.
- Prepare Foot Blocks as shown in detail, then place into position under Bottom BuilderBoard, marking their positions.
- Remove BuilderBoard, Pre-Drill using 9/64" bit, and attach Foot Blocks.

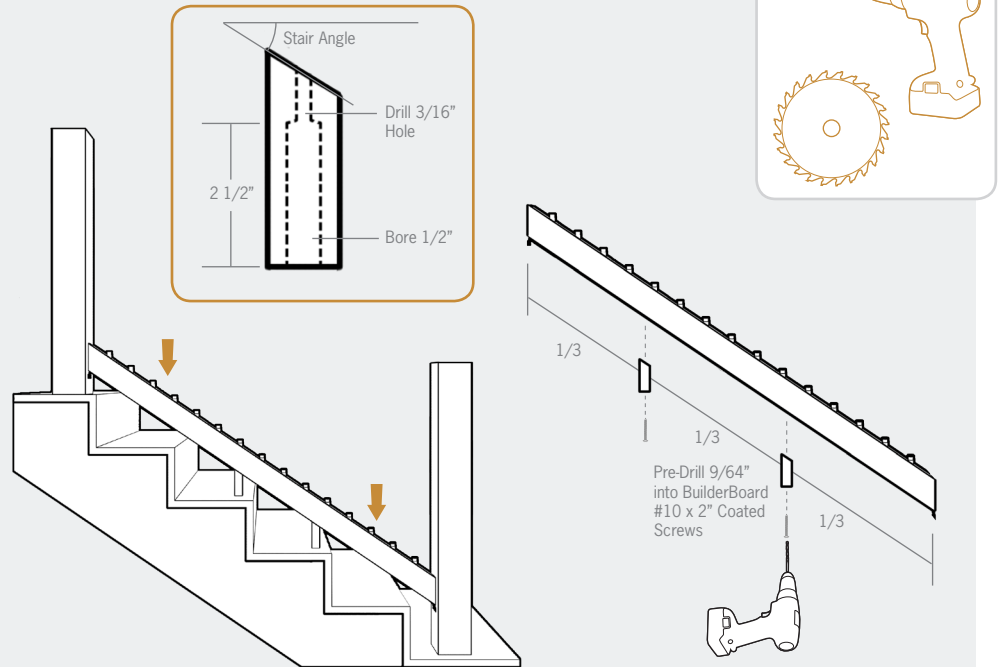

For sections up to 6': Place one Foot Block in the center of the rail

For sections 6' to 8': Space two Foot Blocks approximately at 1/3 intervals on the rail

6 MEASURE AND TRIM TOP POST AND TOP POST SLEEVE

- Temporarily place Bottom BuilderBoard in position and install a Baluster on each end. Place the Top BuilderBoard on the Balusters.
- Mark the top of the Top BuilderBoard.
- Remove Post Sleeve and trim to length, then Trim Post to same length.
- Replace Post Sleeve and slide on Post Skirt.

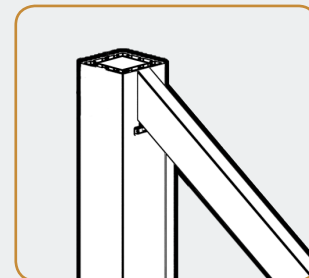
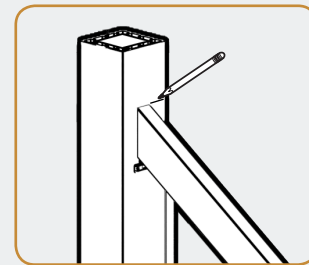
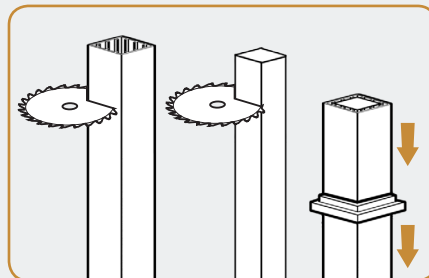
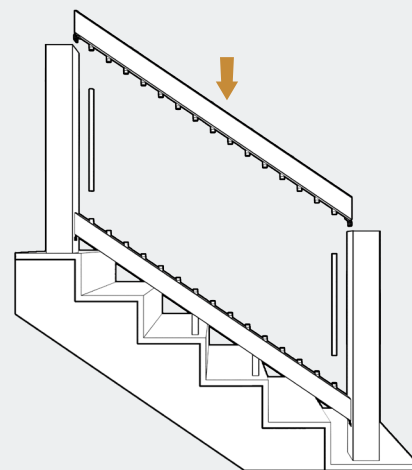

Post Sleeves should be flush with Top BuilderBoard.

7

MEASURE AND TRIM BOTTOM POST AND POST SLEEVE

- Mark where Top BuilderBoard meets Bottom Post Sleeve.
- Remove Post Sleeve and trim to stair angle. Replace Post Sleeve.
- Use Post Sleeve to mark the angle of cut on Post. Remove Post Sleeve.
- Using a straight edge, draw a line roughly 1/8" below previous mark on Post.
- Trim Post at lower line.
- Replace Post Sleeve.
- Slide on Post Skirts.

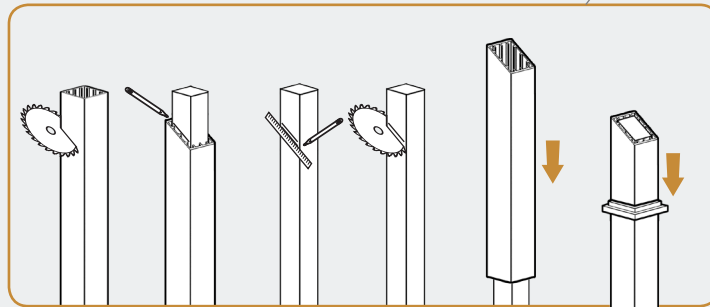
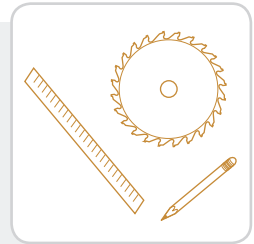
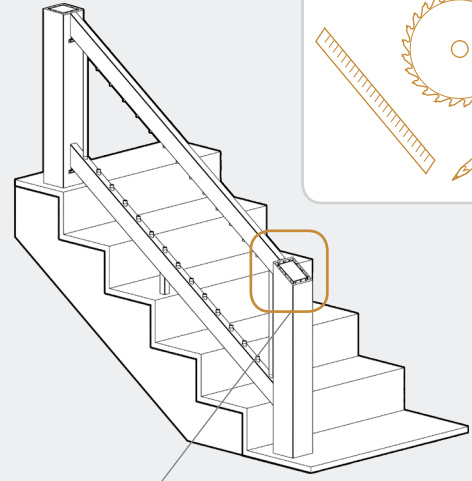
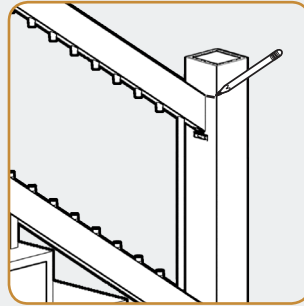

8

INSTALL BOTTOM RAIL, BALUSTERS, AND TOP RAIL

- Move Bottom BuilderBoard into place and secure. Pre-Drill through Brackets with 9/64" bit.
- Place Balusters onto Baluster Connectors.

For ease of connecting Balusters, attach only 1 end of Top BuilderBoard and rotate down, fitting one Baluster at a time.

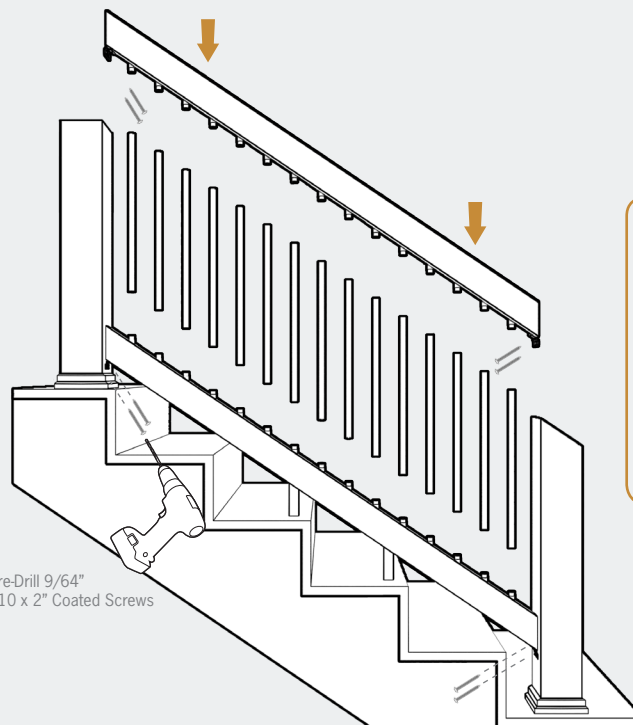

Pre-Drill 9/64"
#10 x 2" Coated Screws

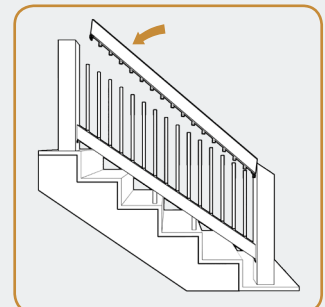
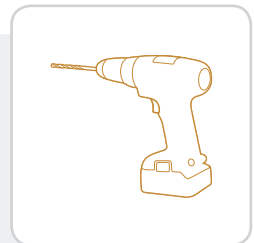

9

INSTALL TOP RAIL

- Finish railing system by applying a TimberTech Square Shouldered profile to the top of the rail assembly.
- Pre-Drill $9/64$ " and secure planks at posts.

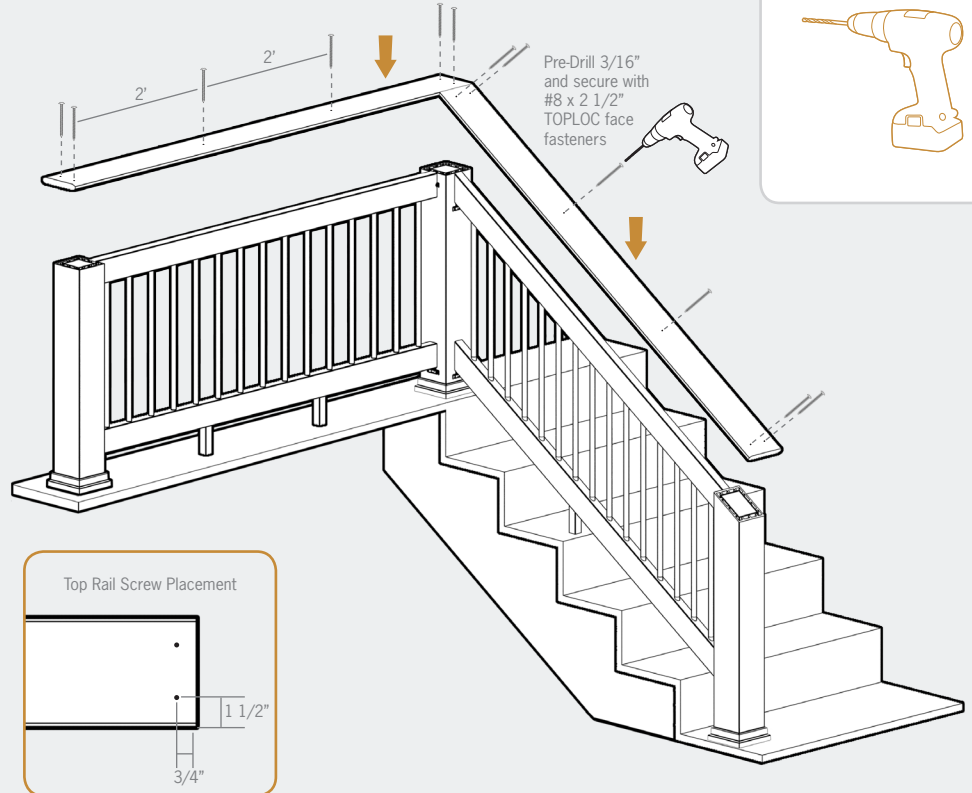

Installing Evolutions Rail™ Builder Style with Glass Infill

Visit www.timbertech.com/installation to view TimberTech installation videos. Consult your local building codes for guard and handrail requirements.

Evolutions Rail™ Builder Boards are available in 6' only for Glass Infill

Measuring Your Railing Area

- Measurements are from center of post. BuilderBoard is produced in 6' lengths to allow for finished end cuts and angles.
- Determine how many 6' BuilderBoards you need and check to be sure you have all the components (and quantities) listed in the chart shown to the right.

Important Information

- ⚠ Glass is not provided and should be secured locally.
- 6' BuilderBoard is designed not to exceed 6' center of post to center of post, respectively.
- Cut slowly, using a fine tooth saw blade to avoid chipping.
- For 42" railing, use 8' Post Sleeves.

Component Dimensions

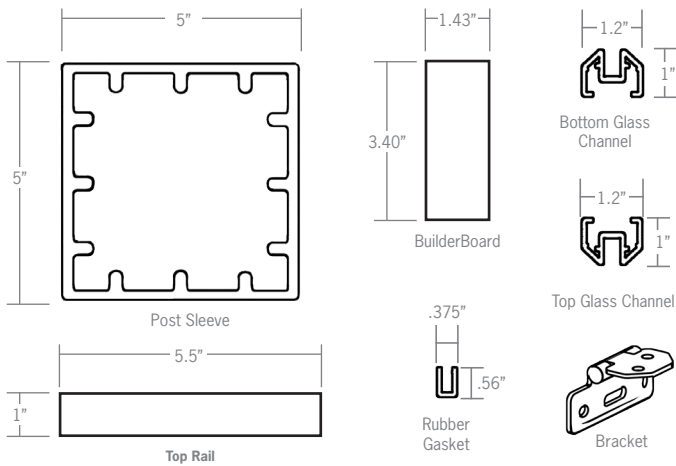

Components Needed For Installing One Builder Style Rail Section	
Components Needed to Complete Rail Sections	2 - BuilderBoards 1 - Deck Plank for Top Rail Timbertech TOPLoc Face Fasteners 2 - Foot Blocks Hardware Kit
Additional Components Needed for Each System	⚠ 1/4 Tempered Glass must be sourced locally (See attached reference sheet). 2 - Post Sleeves 2 - Post Skirts Glass Channels End Coating- Optional
Hardware Needed to Complete 6' Rail Sections	Hardware Mounting Kit: 4 - Hinged Brackets 11 - #10 x 2" Screws 8 - #10 x 7/8" Screws 4 - #10 x 1.5" Screws 1 - Torx Driver Bit

Tools Required

- Miter Saw
- Drill
- Drill Bits: 7/64", 9/64", 3/16", & 1/2"
- Tape Measure

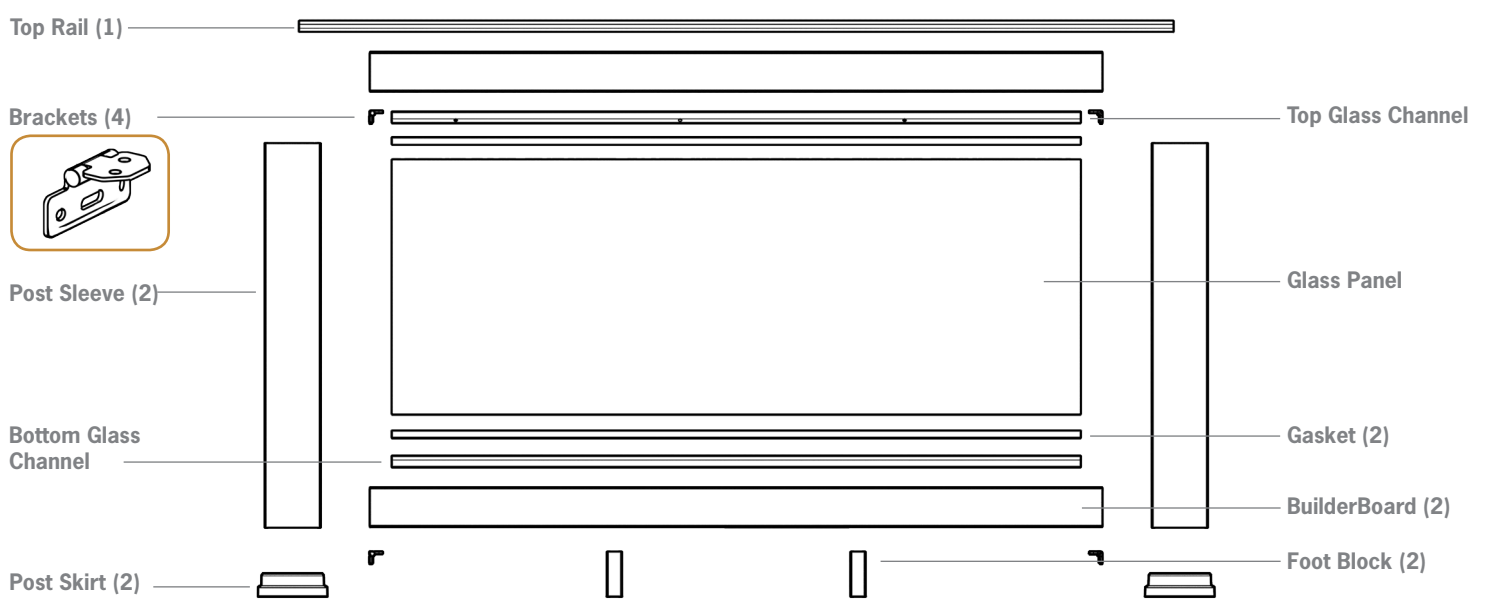

**DIMENSIONAL CONSTRAINTS
FOR STRAIGHT SECTION**

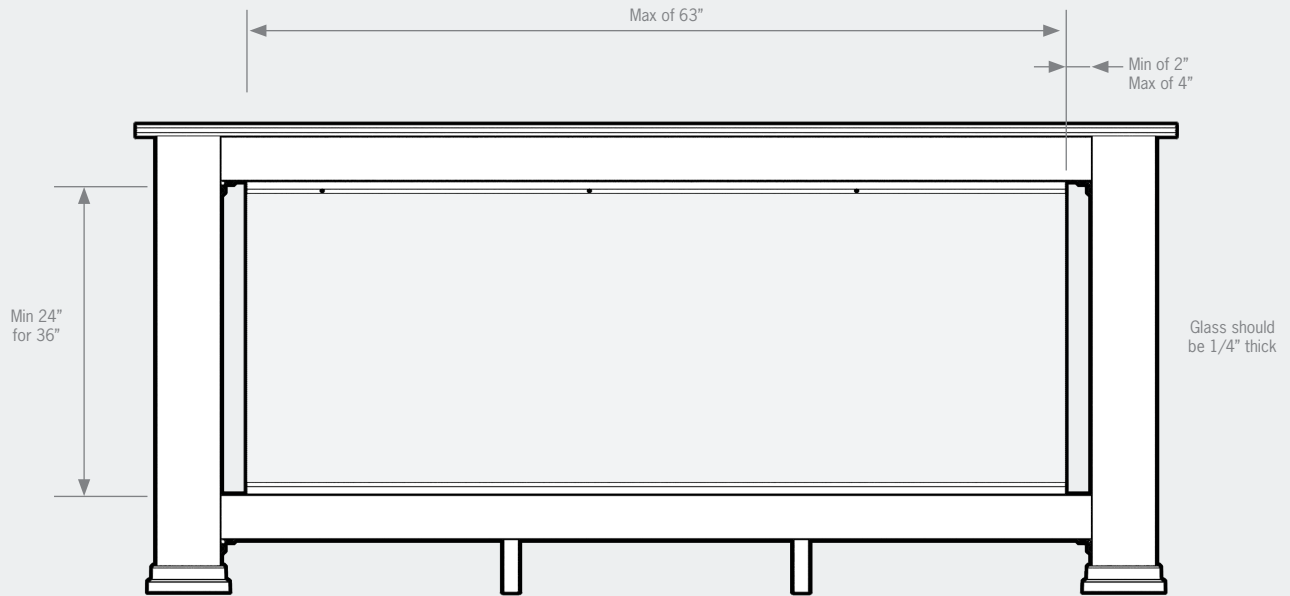

**DIMENSIONAL CONSTRAINTS
FOR STAIR SECTION**

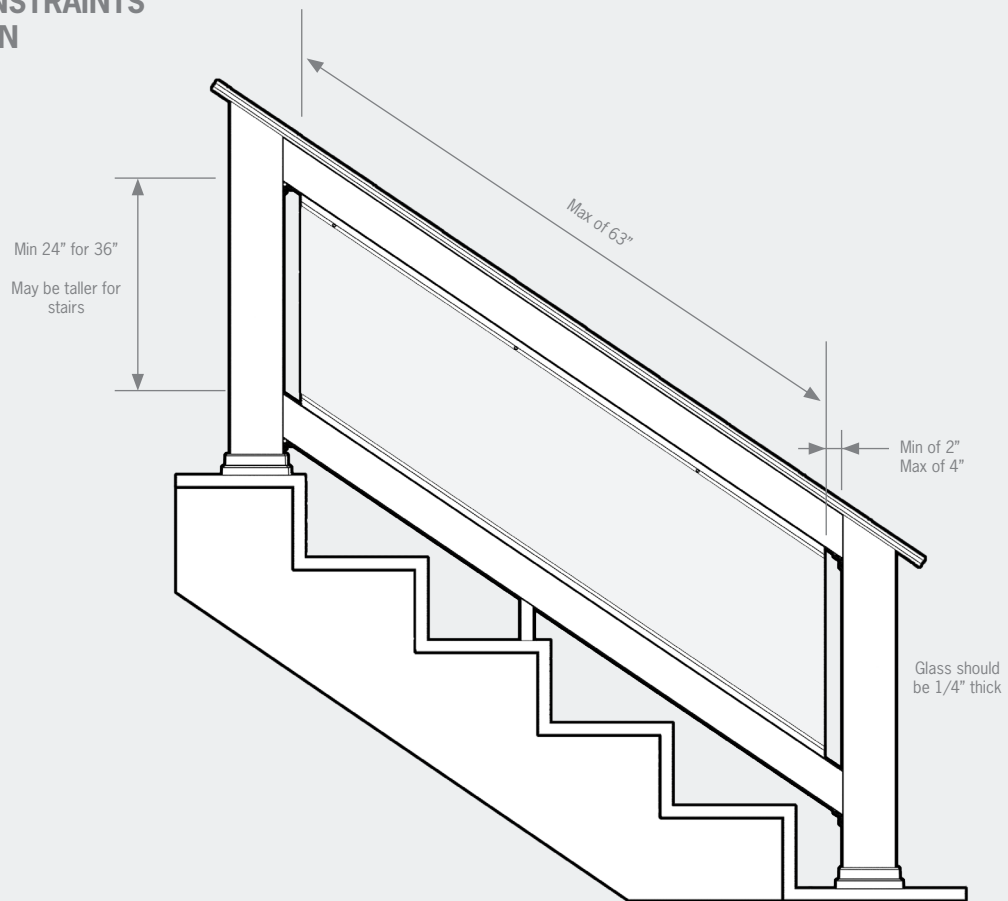

1

CUT POSTS AND TEMPORARILY INSTALL POST SLEEVES

- Posts must be positioned no more than 6' on center, and must be plumb.
- Trim 4x4 Post to a min of 35 1/2" (for 36") and 41 1/4" (for 42) above finished deck surface.
- Slide uncut Post Sleeves over 4x4 posts (do not force).

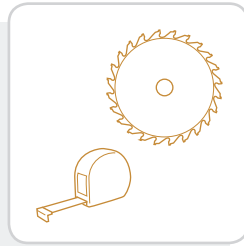
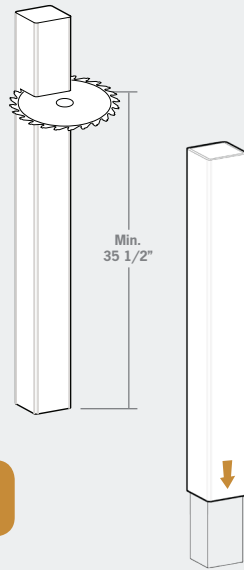

⚠ Do not cut Post Sleeves in this step.

2

MEASURE AND CUT BUILDERBOARDS

- Measure between posts. Cut BuilderBoards.

For best results, cut both ends of BuilderBoards.

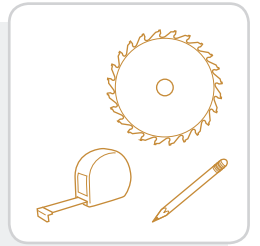
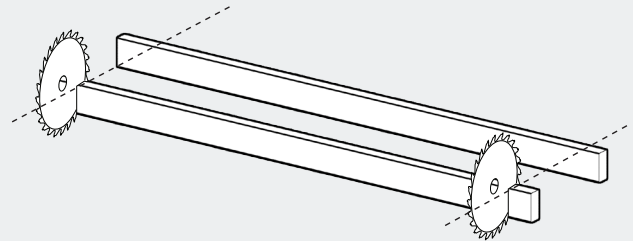

3

ATTACH HINGE BRACKETS AND FOOT BLOCKS TO BOTTOM BUILDERBOARD

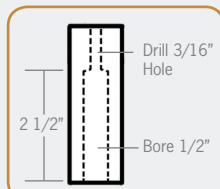

Foot Block Preparation

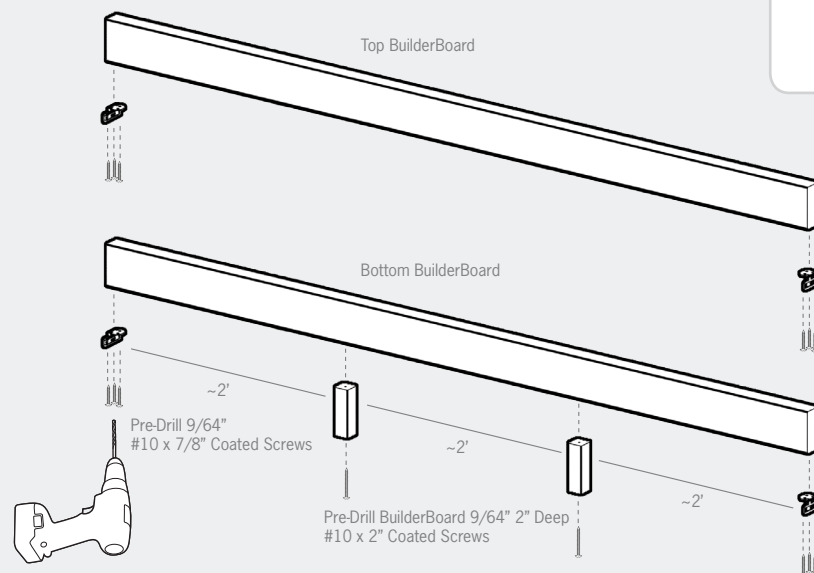

Place two Foot Blocks approximately at 2' intervals on the rail

4 TRIM GASKETS AND GLASS CHANNELS

- Using BuilderBoard length as reference, cut Gaskets and Glass Support Extrusions to length.

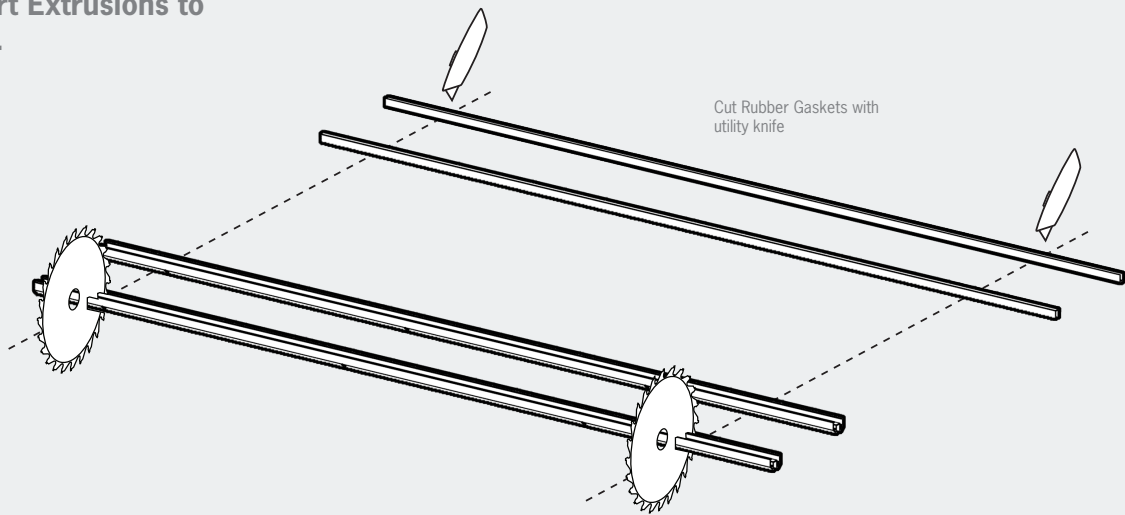
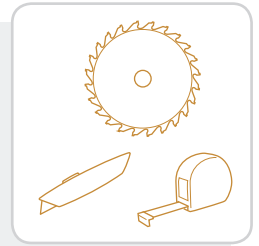

5 TEMPORARILY ASSEMBLE INFILL

- To find height of Post Sleeve cuts, temporarily fit together infill as shown. Do NOT screw anything together.

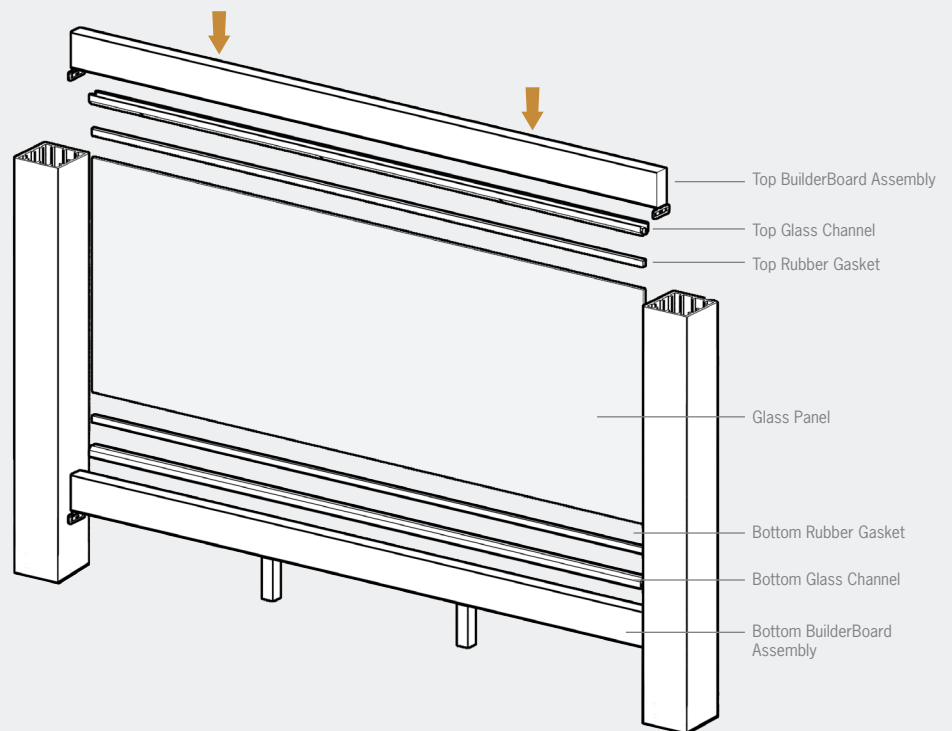

6 MARK AND CUT POST SLEEVES

- Mark the top of the Top BuilderBoard on the Post Sleeves.

Post Sleeves should be flush with the Top BuilderBoard.

- Slide Post Sleeves off posts and cut to appropriate length.

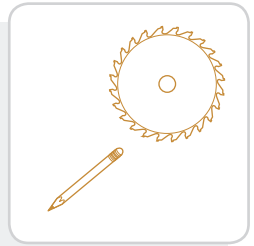
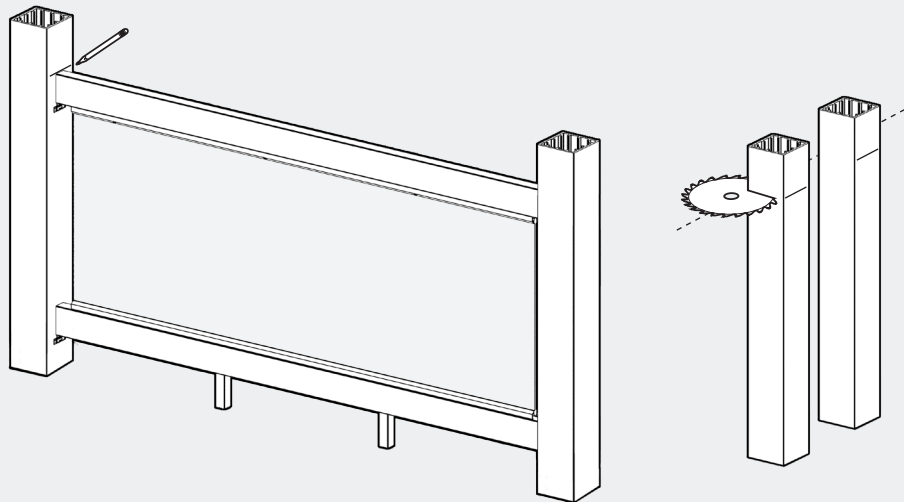

7 INSTALL BOTTOM BUILDERBOARD AND BOTTOM GLASS CHANNEL

- Replace Post Sleeves and Skirts.
- Install Bottom BuilderBoard by Pre-Drilling through Brackets with 9/64" bit and attaching with provided screws.
- Install Bottom Glass Channel. Pre-Drill through existing holes and attach with screws.

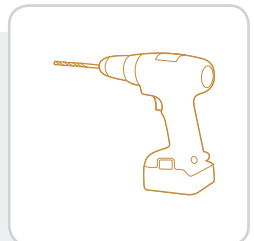
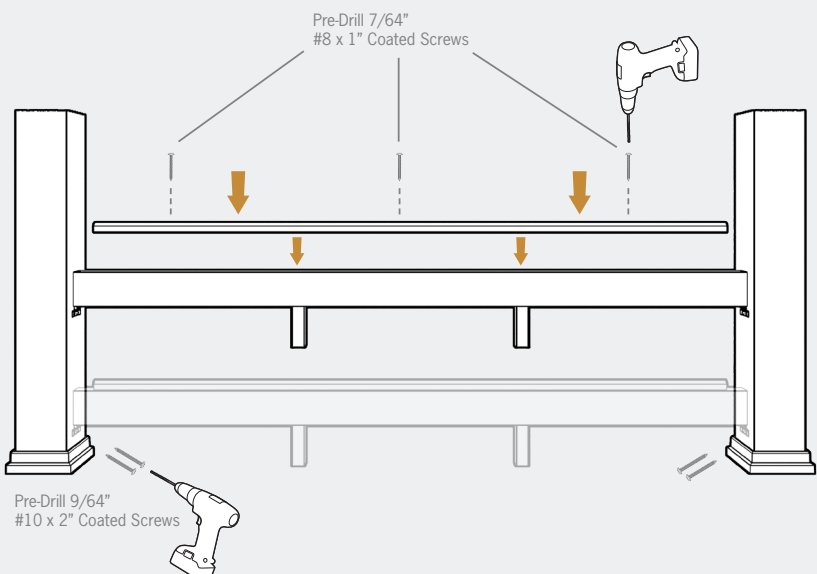

8

INSTALL GASKET AND GLASS PANEL

- Fit Bottom Gasket onto bottom of glass panel and fit assembly into channel in Bottom Glass Channel.

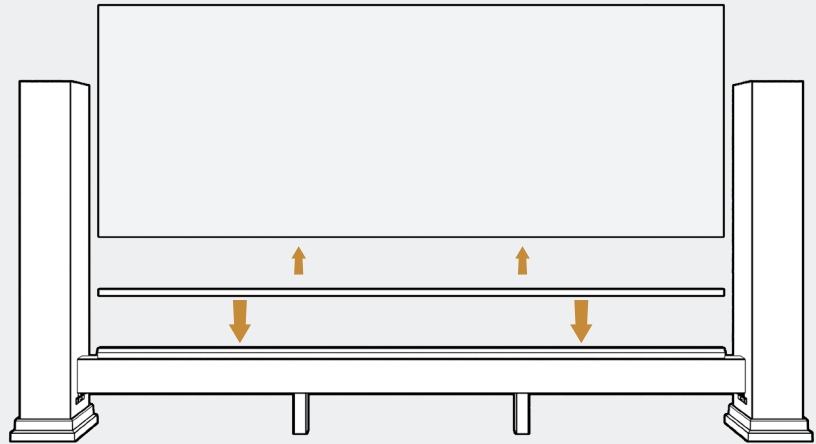

9

INSTALL TOP GASKET, TOP GLASS CHANNEL, AND TOP BUILDERBOARD

- Fit Gasket onto top of glass panel, followed by the Top Glass Channel.
- Place Top BuilderBoard over glass panel assembly and secure.
- Secure

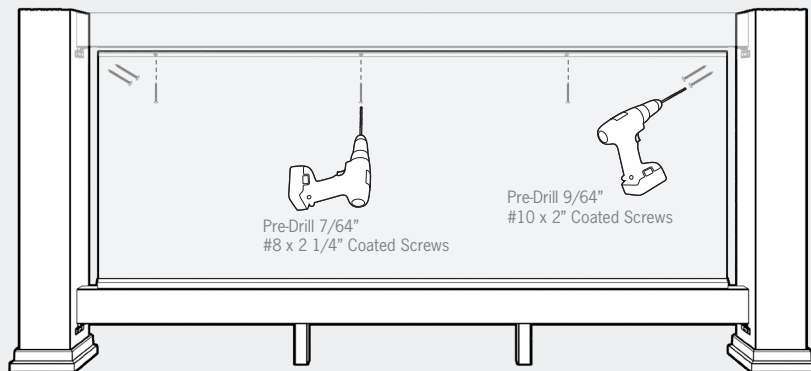
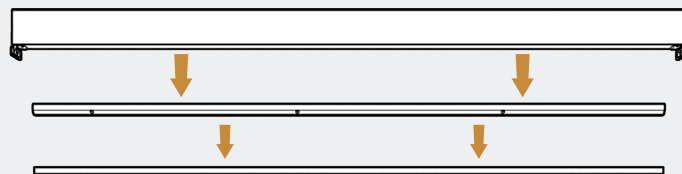
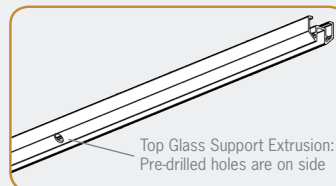

10 INSTALL TOP RAIL

- Cut Planking so that any seams fall at the center of a post. Miter the planks at corner posts.

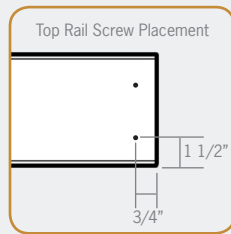
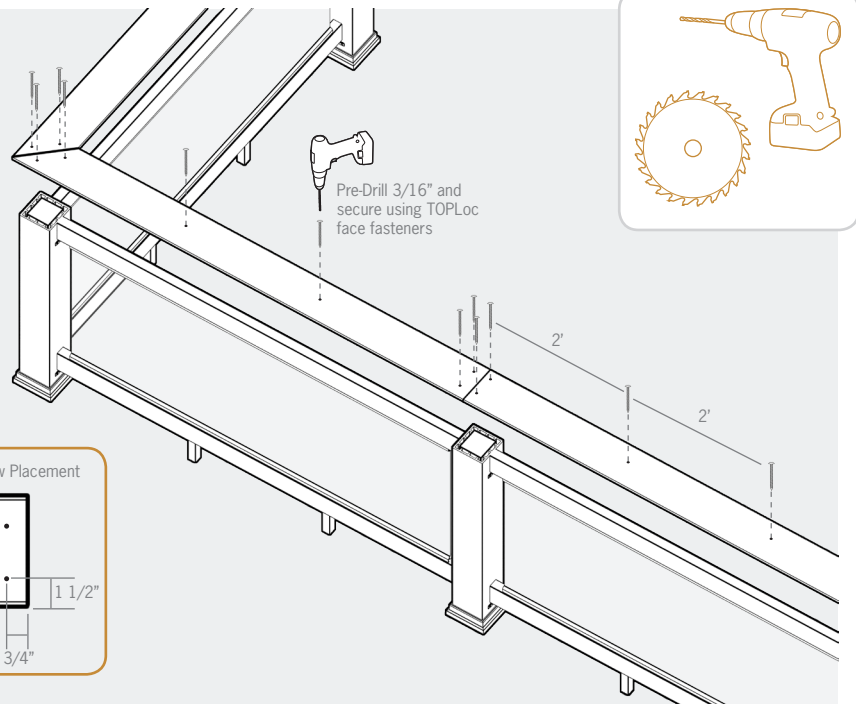

If your rail has stair sections, start installing the cap at the stairs. Wait until all rail sections are complete before beginning Top Rail installation.

1

CUT POSTS AND TEMPORARILY INSTALL POST SLEEVES

- Trim post a min of 35 1/2" (for 36") or 41 1/2" (for 42") above finished deck surface.
- Slide Post Sleeve over 4x4 Post (do not force).
- Post may need to be slightly taller for stairs.

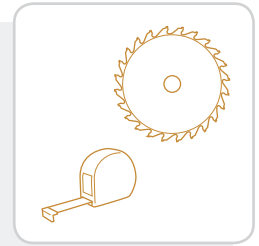
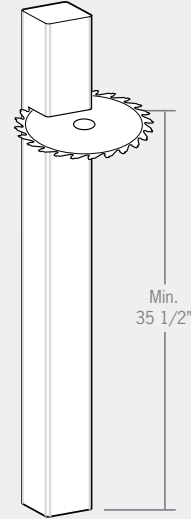
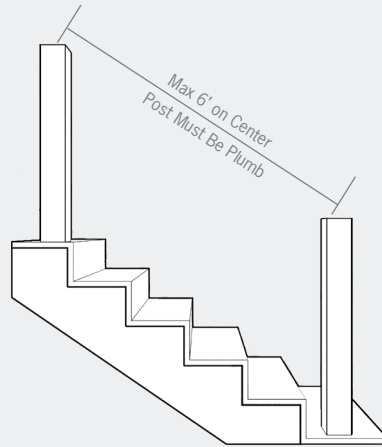

 Do not cut Post Sleeves in this step.

2

MEASURE AND TRIM BUILDERBOARDS

- Position a BuilderBoard on the stairs against the Top and Bottom Post Sleeves.
- Mark the length and angle at each post.
- Trim the ends of the BuilderBoard. Check the fit at Top and Bottom Rail locations, then trim a duplicate BuilderBoard for the Top Rail.

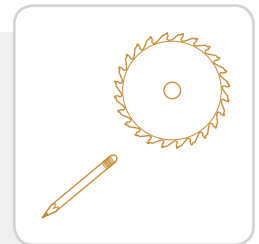
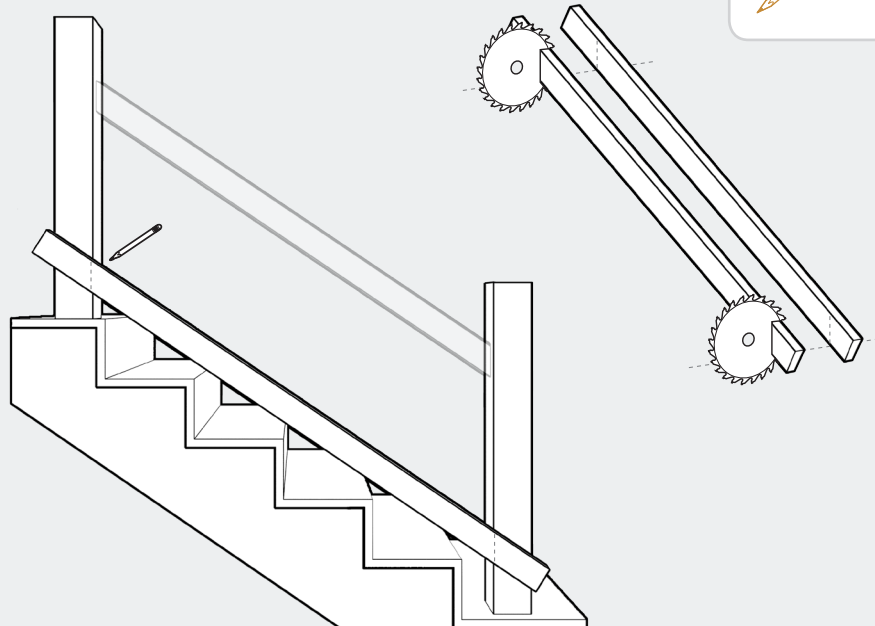

3

TRIM GASKETS AND CLASS CHANNELS

- Using BuilderBoard lengths for reference, determine length for Glass Channels and Gaskets, then cut to length at stair angle.

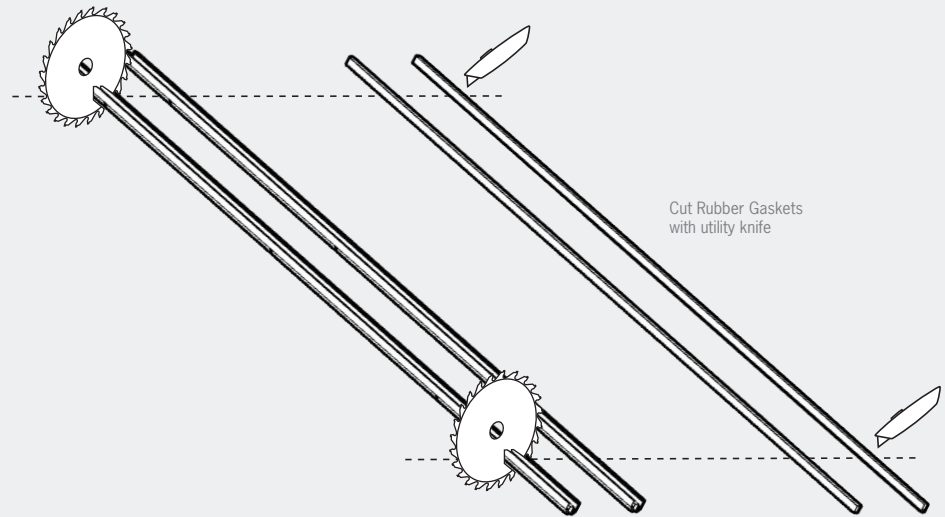
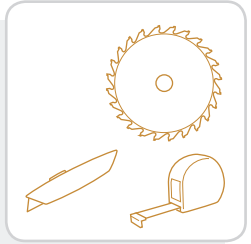

4

ATTACH HINGE BRACKETS TO BUILDERBOARDS

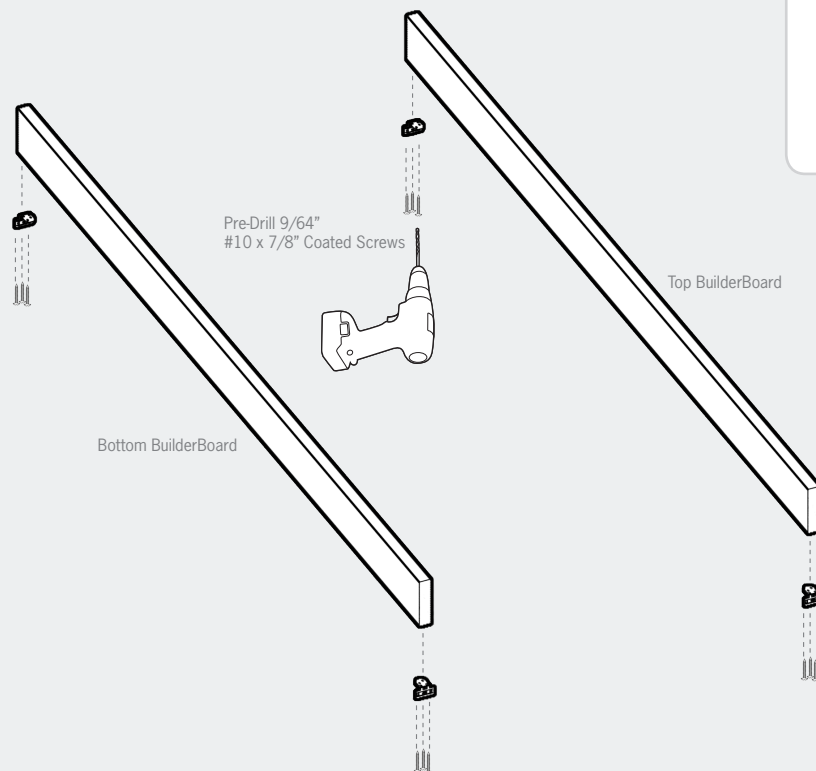

5 INSTALL FOOT BLOCKS

- Temporarily install Bottom BuilderBoard.
- Place Foot Blocks in position under Bottom BuilderBoard, marking their locations.
- Remove BuilderBoard, Pre-Drill using 9/64" bit, and cut and attach Foot Blocks.

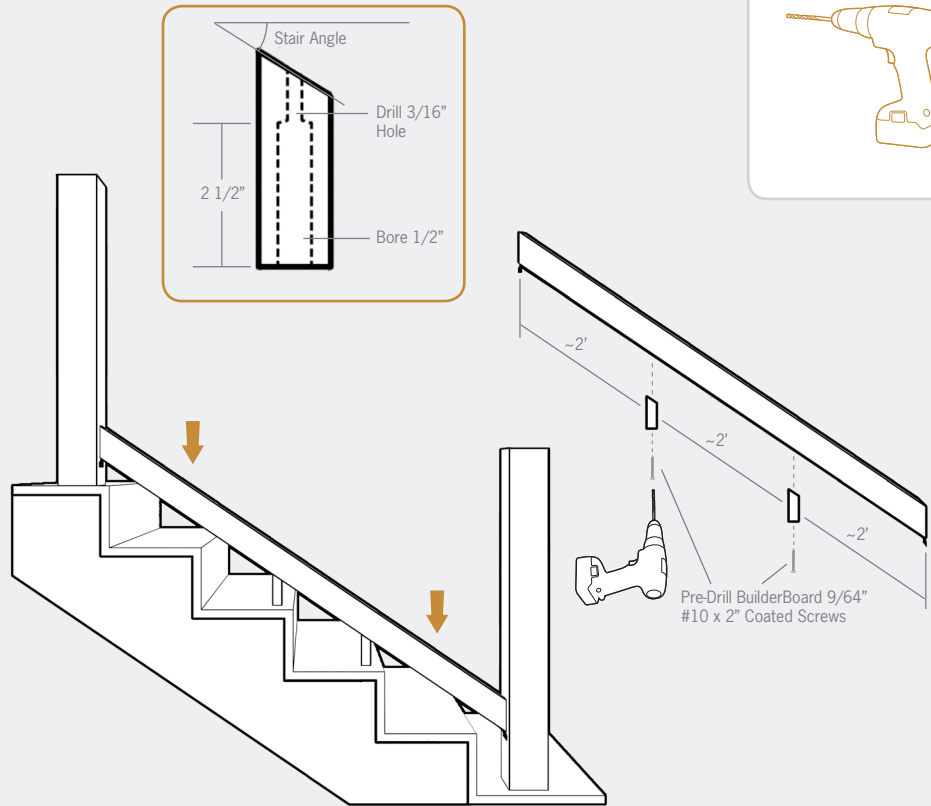

6 MEASURE AND TRIM TOP POST AND TOP POST SLEEVE

- Temporarily install infill from bottom up: Bottom BuilderBoard assembly, Bottom Glass Channel, Gasket, glass panel, Gasket, Top Glass Channel, Top BuilderBoard assembly.
- Mark the top of the Top BuilderBoard.
- Remove Post Sleeve and trim to length, then Trim Post to same length and replace Post Sleeve.

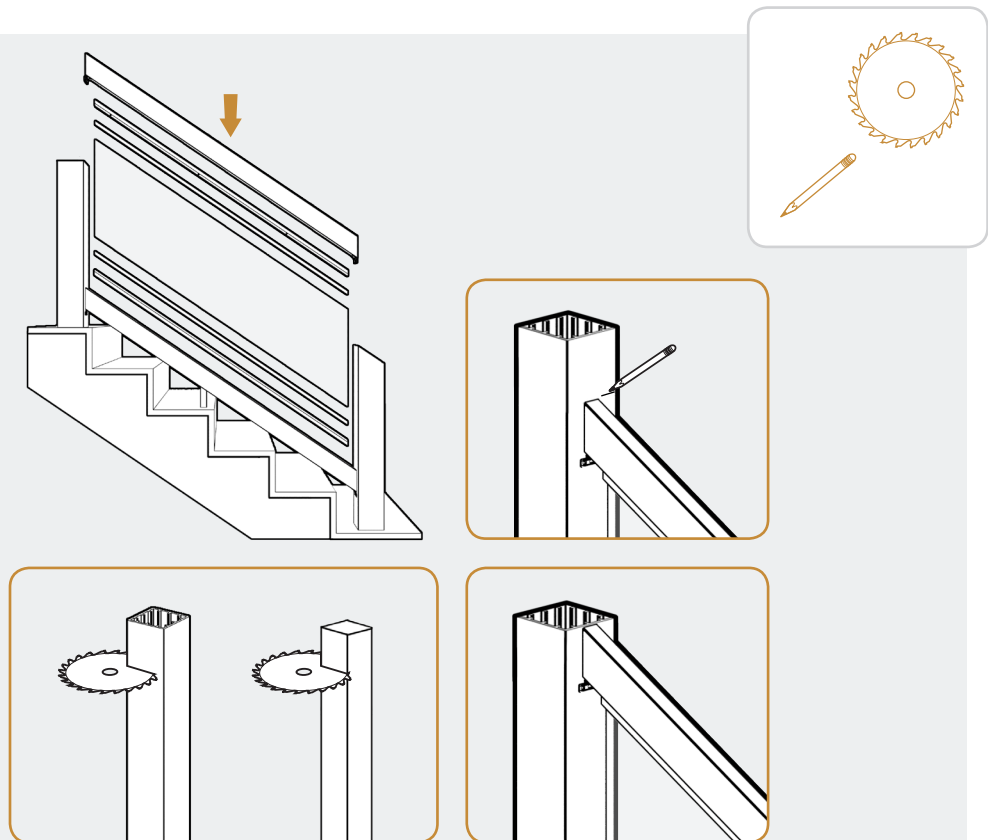

Post Sleeves should be flush with top BuilderBoard.

7 MEASURE AND TRIM BOTTOM POST AND POST SLEEVE

- Mark where Top BuilderBoard meets Bottom Post Sleeve.
- Remove Post Sleeve and trim to stair angle. Replace Post Sleeve.
- Use Post Sleeve to mark the angle of cut on Post. Remove Post Sleeve.
- Using a straight edge, draw a line roughly 1/8" below previous mark on Post.
- Trim Post at lower line.
- Replace Post Sleeve.
- Slide on Post Skirts.

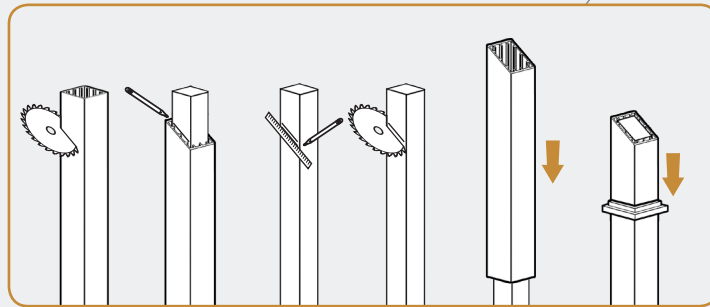
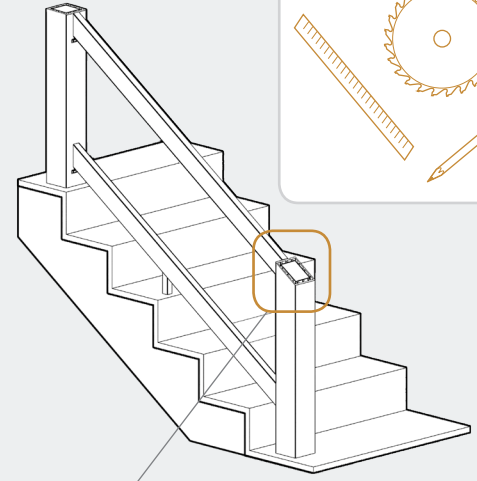
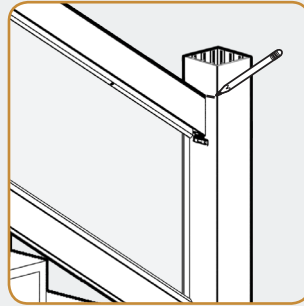

8 INSTALL BOTTOM RAIL AND BOTTOM GLASS CHANNEL

- Move Bottom BuilderBoard and Bottom Glass Channel into place and secure.

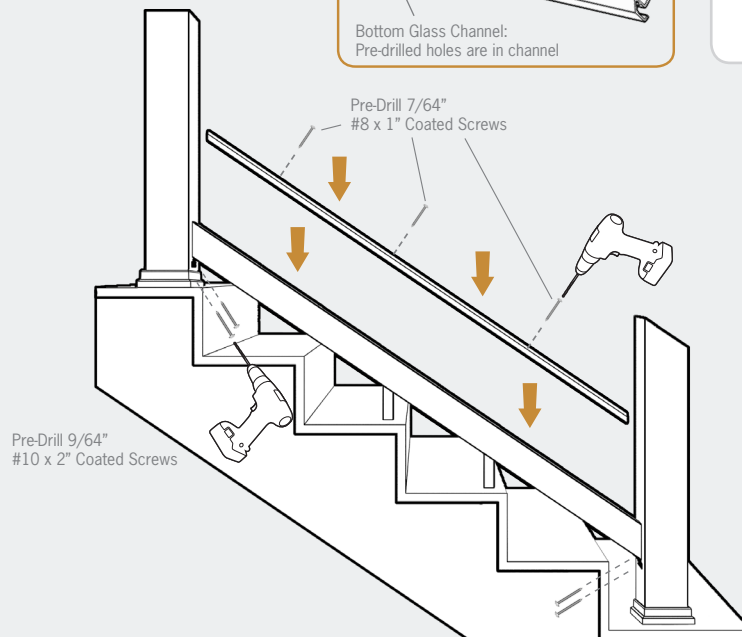
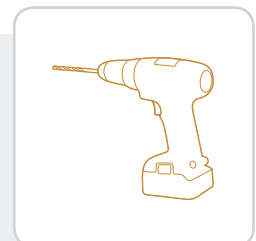
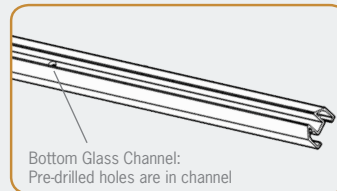

9

INSTALL GASKET AND GLASS PANEL

- Fit Bottom Gasket onto bottom of glass panel and fit assembly into channel in Bottom Glass Channel.

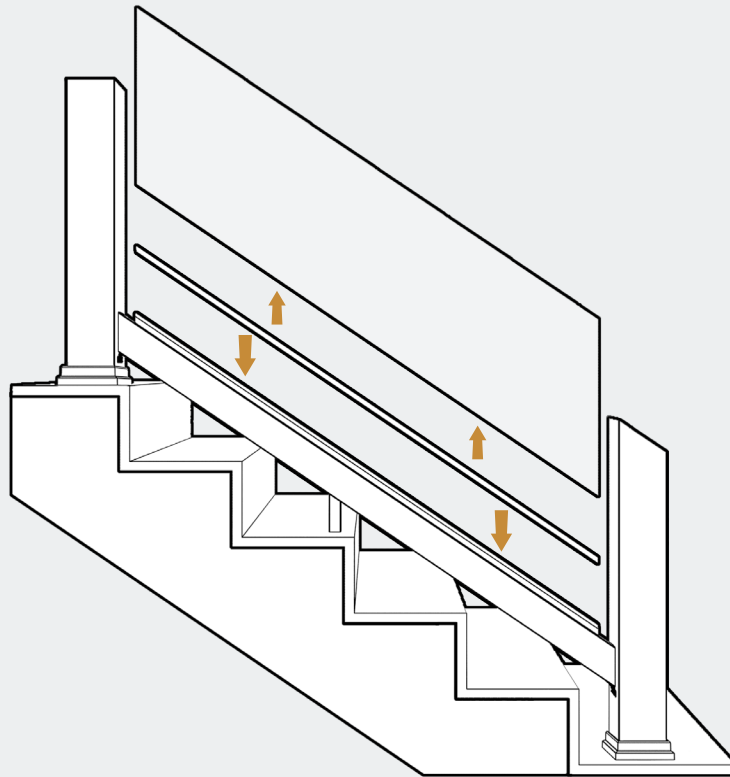

10

INSTALL TOP RAIL AND TOP GLASS CHANNEL

- Fit Gasket onto top of glass panel, followed by the Top Glass Channel.
- Place Top BuilderBoard over glass panel assembly and secure.

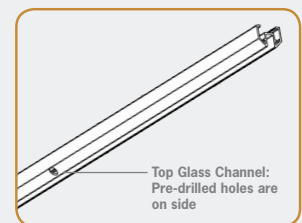
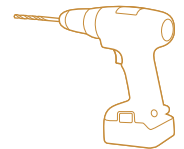
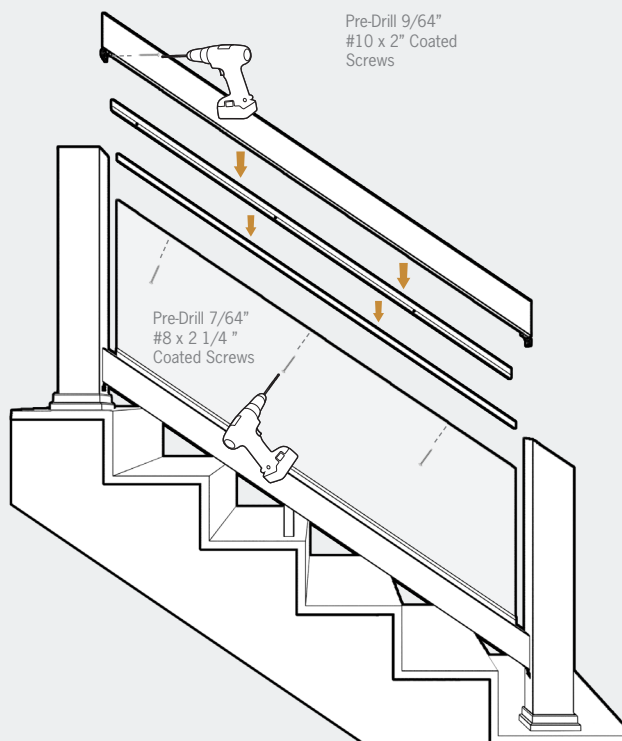

11 INSTALL TOP RAIL

- Finish railing system by applying a TimberTech Square Shouldered profile to the top of the rail assembly.
- Pre-Drill 3/16" and secure planks at posts.

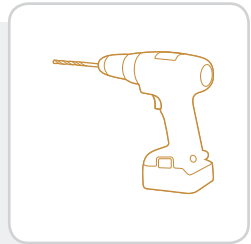
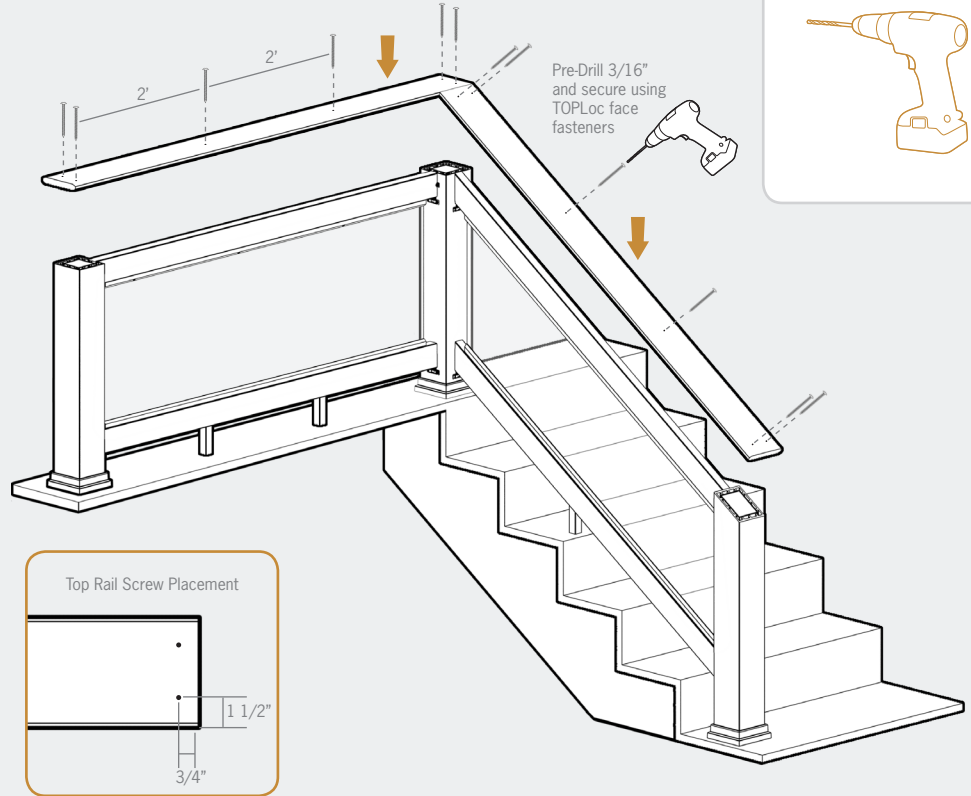

**Evolutions Rail™
Builder Style
Installation Guide**



TimberTech
894 Prairie Avenue
Wilmington, OH 45177
timbertech.com
1.800.307.7780